



INTERIOR SIGNAGE PROGRAM

UPDATED JANUARY 2020

TABLE OF CONTENTS

- 2 Introduction, Wayfinding Basics
- 3 University Branding, Crest & Shield, Green & Gold Stripe
- 4 Typography
- 5 Braille & Tactile Features
- 6 ST 1.0 Room & Personnel ID
- 7 ST 2.0 Washrooms, Wall-mounted
- 8 ST 2.4 Washrooms, Projecting
- 9 ST 2.7 & ST 2.8 Stair Identification & Level Identification
- 10 ST 3.0 Regulatory Signs
- 12 ST 4.0 Room ID - Academic, Administrative
- 13 ST 4.8 Room ID - Student Residences
- 14 ST 5.0 Information Signs
- 15 ST 6.0 Directional Signs
- 16 ST 7.0 Large Goal ID
- 17 ST 8.0 Directories & Sub-Directories
- 19 ST 9.0 Faculty/Department Identities
- 20 ST 10.0 Interior Building Identification & Pedways
- 21 Installation Guidelines
- 25 Maintenance

INTRODUCTION

The purpose of this document is to guide the administration, design, implementation, and maintenance of signs applied within University of Alberta buildings. This document describes the graphic and visual standards for wayfinding signs, their sizes, roles and their maintenance, especially for facilities constructed after 2008.

A wayfinding system is made up of subsystems of signs that apply to individual buildings or portions of a facility. Each sign, or subsystem of signs, is intended to communicate in a uniform, consistent, understandable, and reliable manner. Wayfinding is about making a coherent network of signs in buildings and facilities, a challenging task given various architectural styles, our long and rich history, and the wide diversity of activities (teaching, research, and hosting) in our buildings.

Words are not really placed within a sign, rather, a communication is determined, and then an appropriate form of sign is selected to communicate that message. In other words, the form follows from the content. This helps each sign harmonize within the larger wayfinding system.

Some pages of this document depict signs that are no longer used or encouraged. Nonetheless, these signs are identified, include a brief explanation for their avoidance, and/or suggest a more effective alternate. These signs are still included in this reference document to assist with migration away from them as opportunities occur.

Wayfinding signs in facilities constructed before 2008 can usually be found in the 1992 document *University of Alberta Sign System Guidelines*. Facilities using this system of signs continue to do so and typically migrate into the standards in this document as renovations or facility renewal allows.

The signs standards and specifications are intended to:

- establish sign continuity
- ensure consistency in presentation
- promote legibility and readability
- ensure our signs are functional, serving the needs of students, staff, and visitors
- guide procurement so that new signs are economical, easy to install and to maintain
- minimize proliferation through careful consideration in planning, placement, and content
- provide for flexible application in different architectural or operational environments

WAYFINDING BASICS

Broadly speaking, each and every wayfinding sign in this document strives to either:

1. **Inform** (Directories, Maps, Regulatory signs);
2. **Direct/point** (Signs with arrows); or
3. **Confirm** (Goal Signs, ID signs)

The three coloured tabs (right) appear on subsequent pages in this manual to assist in matching a communication need with an appropriate sign type.

Generally speaking, a sign within a larger system of signs is more effective if it is tasked with only one of the three basic duties – either **inform** or **direct** or **confirm**. This helps ensure that information is optimized for the needs of the person viewing the sign (rather than the person posting the sign), and doing so at appropriate points in their journey. When a piece of information is repeated in a building’s wayfinding system, it tends to follow this three-part sequence.

The choices of information, words, and symbols on any sign are as important as the sign itself. Sign content strives to:

- choose friendly or neutral language
- be optimized for the needs of the viewer
- eliminate unnecessary detail or ornament
- use clear, direct, plain, or everyday language
- avoid or minimize ambiguity
- be accurate and concise

Specific choices of language or wording might vary from one type of sign to another and strive to be optimized for the situational needs of the viewer. As an example, a department with a very long name might wish to use an abbreviated form of its name on a directory, an acronym form on a pointer sign, but a fully spelled out name on the last goal sign that is near their door and reception area. Consistency in formatting is usually desirable, but minor deviations in language or content that improve the viewers experience is desirable. Optimizing each sign for the viewer is a key philosophy for all signs in the wayfinding system. Additional formatting and editorial recommendations can be found throughout this document.

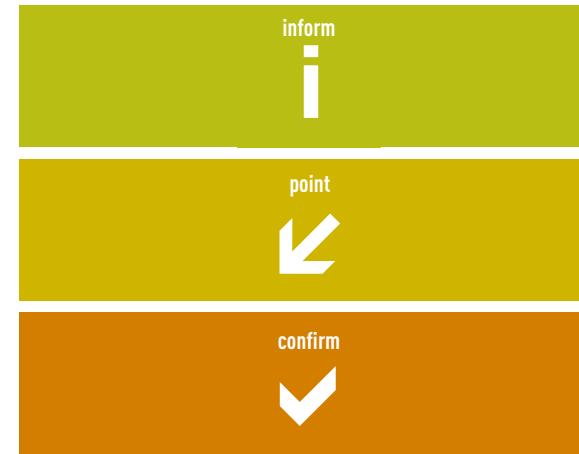

UNIVERSITY BRANDING

The University of Alberta wayfinding system is optimized to assist students, visitors, alumni, and guests efficiently navigate our buildings and facilities. At the same time, some branding elements have been incorporated into our signs, usually a green and gold stripe.

The University of Alberta logo also appears on a few items, typically in two instances:

1. Building directories, or
2. At or within administrative reception areas

The University of Alberta logo is generally absent from other base building signs (bathroom identification, stairwell signs, work station ID, or directional pointer signs). The green and gold stripe is included as a branding element on most other wayfinding items.

When required, all logos and brand elements are to follow *University Brand Guidelines* which are maintained and distributed by University Brand and Marketing, a part of University Relations.

CREST & SHIELD

The University of Alberta logo is made up of two components: a shield (incorporating a book – symbolizing learning and education – and components derived from our provincial flag (mountains, foothills, and wheat) with a wordmark, typically the words “University of Alberta” or official subunit wordmark. A subunit logo is one which includes the words “University of Alberta” and the official faculty and/or department name. Subunit logos are typically relevant in reception areas or administrative headquarters and usually produced using single-colour materials. Information on this topic is posted at www.ualberta.ca/toolkit/visual-identity and the distribution of official University of Alberta logos is managed by University Brand & Marketing.

GREEN & GOLD STRIPE

The University of Alberta’s official colours are used in a green and gold gradient band, as below. This element is printed in a four-colour decal process with a clear overlamine to improve durability and resist fading.

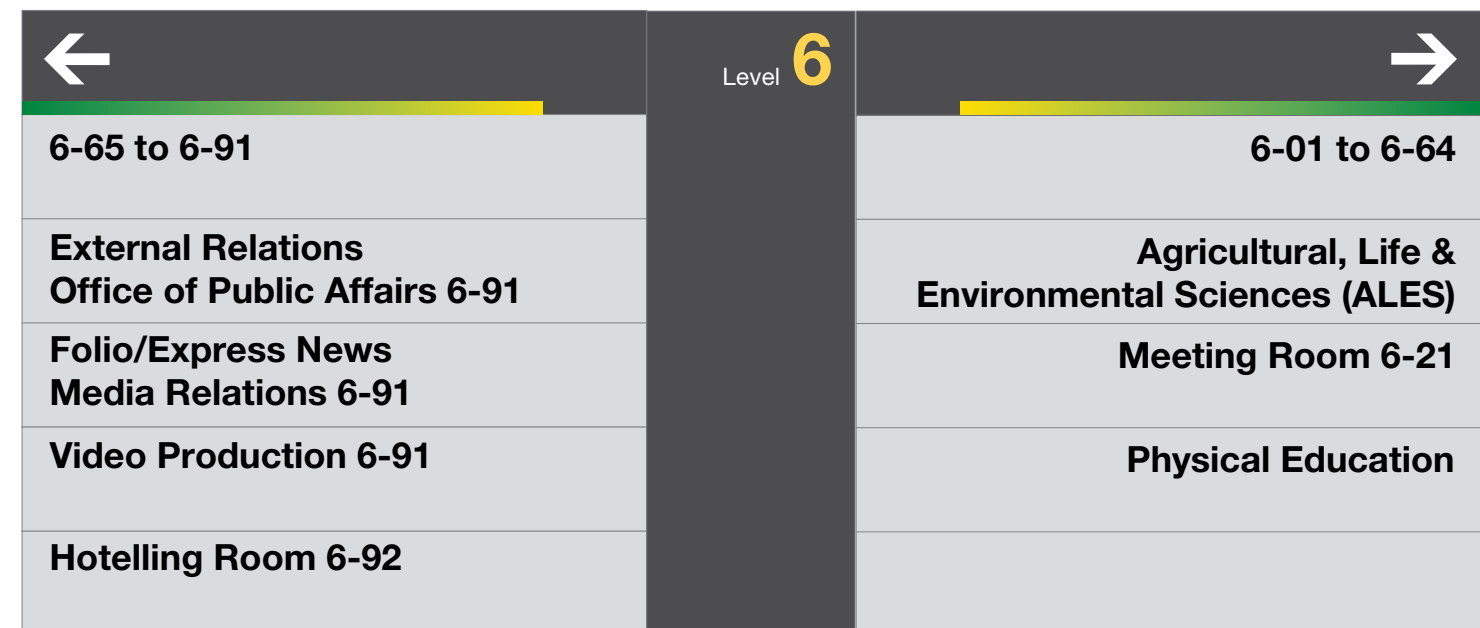
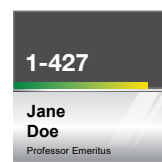
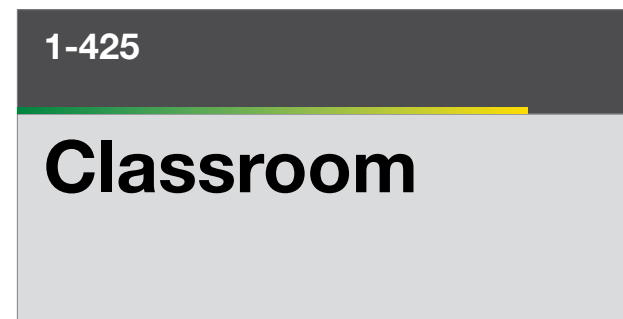
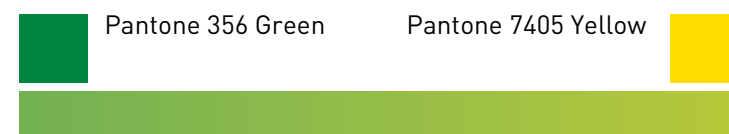

Full Logo,
horizontal format,
multi-faculty or
multi-department items



Sub-unit Logo
Two Tiers
(Faculty/Department
headquarters)



Sub-unit Logo
Three Tiers
(Faculty/Department
headquarters)



Here are examples of different ways that branding elements are part of larger wayfinding system.

TYPOGRAPHY

Designed in 1957, Helvetica is a sans-serif font used extensively in many wayfinding systems and visual design programs. This typeface has been used at the University of Alberta continuously since the 1970s. Its use also harmonizes with several key institutional peers:

- The Government of Alberta Visual Identity Manual defines Helvetica as its primary typeface
- Alberta Health Services Brand Toolkit uses and recommends Helvetica for sake of clarity, neutrality, and versatility
- The Government of Canada Federal Identity Program has widely and consistently used Helvetica for Signage and Visual Standards since 1987

Helvetica has also been used in many international transportation settings, can be used for legibly typesetting in almost any language, and is one of the world's most prolific typefaces. This is advantageous for the sustained use on wayfinding items as we engage with local, national and international visitors.

Helvetica creates efficiencies in maintenance and upkeep. The sizing of text in Helvetica is easy to measure by maintenance staff, in part because 100 pt = 1.00 inch. Generally speaking type is sized to nearest inch or half-inch: 0.50 inch, 0.75 inch, 1.00 inch, 1.50 inch, 2.00 inch, 3.00 inch, and so on. This makes the replacement of wording on signs simpler and easier to administer.

Helvetica is also useful for those instances where we require tactile lettering (see details next page).

Type formatting on signs strives to allow quick and efficient processing of language and information. Uppercase lettering is not favoured on most signs because it is harder to read quickly than title-case or lowercase wording. Uppercase lettering also occupies more space than lowercase lettering. Word choices on any sign should strive for plain or everyday language for sake of economy and inclusiveness. Our visitors may be young, new to using English or French as an additional language, be in distress, or may be cognitively overwhelmed.

Helvetica is not readily available in most administrative settings, however. For this reason, staff templates (distributed for paper based items on page 6) can use Arial. Arial is a reasonable substitute for Helvetica on staff identification paper-based sign inserts, allowing users to maintain their workstation identification signs independently.

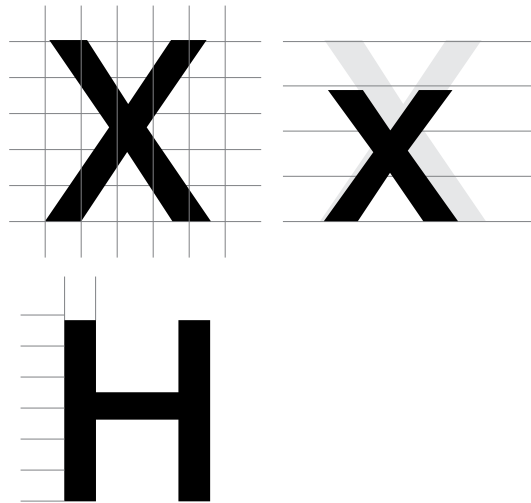

Type Proportion

Width

Ratio of width to height for an upper-case letter 'X' should be between 3:5 and 1:1. Fonts for an upper-case 'X' should not be wider than they are tall.

Height

Ratio for the height for a lower-case letter 'x' to the height of an upper-case letter 'X' should be about 3:4 (lower-case letters should be about 75% the height of upper-case letters).

Weight

The stroke width to height ratio should be between 1:5 and 1:10. Text should not be too thin and light or too heavy.

Entrance Faculty Registration

Helvetica Neue 45 Light

ABCDEFGHIJKLMNOPQRSTUVWXYZ
abcdefghijklmnopqrstuvwxyz
1234567890

Helvetica Neue 55 Roman

ABCDEFGHIJKLMNOPQRSTUVWXYZ
abcdefghijklmnopqrstuvwxyz
1234567890

Helvetica Neue 75 Bold

ABCDEFGHIJKLMNOPQRSTUVWXYZ
abcdefghijklmnopqrstuvwxyz
1234567890

Helvetica Neue 57 Condensed

ABCDEFGHIJKLMNOPQRSTUVWXYZ
abcdefghijklmnopqrstuvwxyz
1234567890

Helvetica Neue 77 Condensed Bold

ABCDEFGHIJKLMNOPQRSTUVWXYZ
abcdefghijklmnopqrstuvwxyz
1234567890

BRAILLE & TACTILE FEATURES

The University of Alberta is inclusive. Our wayfinding also considers circumstances beyond our typical staff and students, including (but not limited to):

- guests with physical/mobility disabilities
- potential future students (those in today's youth day camps and sports camps)
- alumni and their families
- international guests (including students, speakers, lecturers, staff, and professors)
- patients undergoing treatment in adjacent Alberta Health Services facilities
- outreach programs and activities

A general principle in any wayfinding system is to eliminate unnecessary information so that it is easy to use by many people. Wording on wayfinding signage strives to be succinct and direct. This saves space and allows the viewer to more quickly process and understand the information. If two signs have the same intent, the one with less language, fewer graphic elements, or fewer details is considered better.

The colouring and lettering sizes on our signs have been selected to maximize visual contrast so that they are practical for those with visual impairment or colour blindness. Surface finishes tend toward matte to minimize glare or reflections.

Most interior directional signs (with arrows) strive to be wall mounted or suspended. Freestanding signs are not favoured because they are potentially hazardous to those with mobility disabilities, they can impede movement in the event of emergency, they generally obstruct efficient movement of students during class changes, or they can obstruct floor cleaning equipment. Suspended signs, or those mounted above doorways, are generally visible even when corridors are congested during class changes. Implicitly, most wayfinding signs are inherently optimized as a *visual* communication.

At the same time, a few sign types in this predominantly visual system are able to include some 'non-visual' features like braille or tactile touch lettering, in particular:

- a) wall mounted washrooms signs (see page 9),
- b) wall mounted floor ID marker signs (page 11), and
- c) wall mounted stair ID signs (page 11).

Letters	a	b	c	d	e	f	g	h	i	j	k	l	m	n	o	p	q	r	s	t	u	v	w	x	y	z
	⠁	⠃	⠉	⠑	⠑	⠑	⠑	⠑	⠑	⠑	⠑	⠑	⠑	⠑	⠑	⠑	⠑	⠑	⠑	⠑	⠑	⠑	⠑	⠑	⠑	⠑
Numerals	1	2	3	4	5	6	7	8	9	0																
	⠼	⠼	⠼	⠼	⠼	⠼	⠼	⠼	⠼	⠼																

Prefix indicator examples:

Numeric	⠼
Letter	⠠
Capital letter	⠠
Capital word	⠠

Punctuation examples:

comma	⠸
period	⠸
hyphen	⠸
colon	⠸

Grade 1 braille examples:

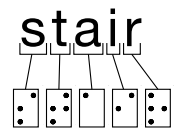
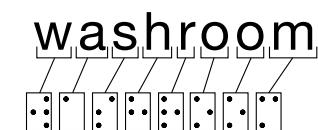
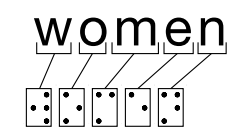

The aforementioned signs incorporate ADA (Americans with Disabilities Act) recommendations for text sizing, language, colour contrast, choice of font, use of tactile lettering, and associated braille, anticipating that a similar Canadian requirement could occur.

Tactile signs are typeset in uppercase because lowercase letterforms are harder to read by touch. There is more geometric variation in letter design with lowercase alphabets (an 'a' is sometimes a circle with a line but in other typefaces resembles a backwards '6') and this readily explains why uppercase letters are favoured by those trained to read by touch. Similarly, the fine details associated with serifed typefaces

are never used for tactile lettering because they make reading by touch more difficult. Helvetica, our signage typeface, is suitable for reading by touch (ADA-compliant) and consistent with tactile signs favoured by Public Works and Government Services Canada (PWGSC).

Elevator control buttons and signs on their door jambs are typically marked using braille and tactile numerals by code, using an independent process and thus not included in this document.

It is useful to know that there are several forms of braille. Those learning braille begin using Grade 1 braille. Letters are represented by a six dot pattern placed with a finger-tip sized area called a cell.

To distinguish between numerals and letters, special characters are placed before some passages of text.

As a braille user's proficiency increases, the speed of reading is further helped by having some characters represented not by just individual letters, but by sounds or contractions. This form of braille is sometimes called Grade 2 braille. However, a newer and more standardized form of braille, known as UEB (Universal English Braille) has been developed and now widely taught in the Canadian education system, especially K to 12. Over time, we can expect that those proficient in braille will increasingly become UEB proficient rather than being Grade 2

users, and especially those coming to the University of Alberta from other Canadian education systems. The use of either Grade 2 or UEB tends to be desirable for those reading longer continuous passages of text, as it saves space and allows a proficient braille user to read more quickly. However, the use of Grade 1 braille on our signs maximizes outreach to all our potential braille users irrespective of their proficiency. It is understood by those who are new to braille, those more recent adopters of UEB, or users of Grade 2 braille.

For these reasons, washroom signs, floor level signs, and stair indicator signs that have braille are done using Grade 1 braille.



ST 1.0 ROOM & PERSONNEL ID

Signage on this page is most closely associated with the identification of workstations and small offices. The bottom portion is from a paper-printout insert, allowing users to conveniently update it with a pdf template. This sign type is also used for identification of custodial rooms, electrical rooms, communications rooms, and other utility rooms.

Templates for users to do their own workstation inserts are found at: www.ualberta.ca/vice-president-facilities-operations/planning/signage-and-wayfinding.

The University of Alberta values diversity, inclusivity, and equity. This has some influence on how we format names on these items. In most cases, words that emphasize gender, marital status, or title (Mr, Mrs, Ms) are not recommended on these signs.

In the post-secondary academic environment, the title 'Dr' is usually omitted from these items, as it does not improve wayfinding and can sometimes be perceived as hierarchical. So, for reasons of collegiality, titles are

not usually present on these items. The inclusion of 'Dr' is generally favoured, however, when used with the general public within medical service environments.

The decision to include a role or job title after the person's name is optional and not required. Examples depicted on this page are for illustrative purposes only.

Educational or professional accreditations, awards, or other titles or certifications are rarely included on these items.

Scale 1:4

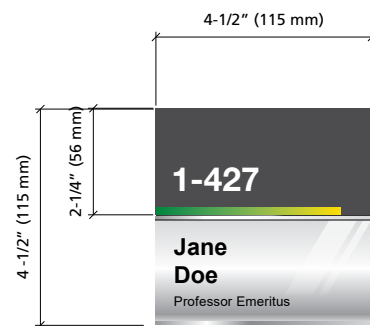

ST 1.1
Single Personnel ID, wall mount

Numeral, matte white Helvetica Neue 75 Bold 50 pt (0.50 inches)

Paper insert 4.50" w x 2.25" h
Name, Arial Bold 35pt
Position/title Arial Regular 20pt

Note: Mr, Mrs, Miss, Dr, and credentials will not be used.

Also:
Pictogram added for Recycle Centre as shown:

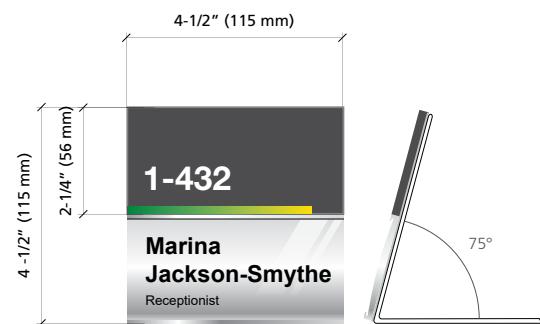

ST 1.5
Single Personnel ID, Desk Stand

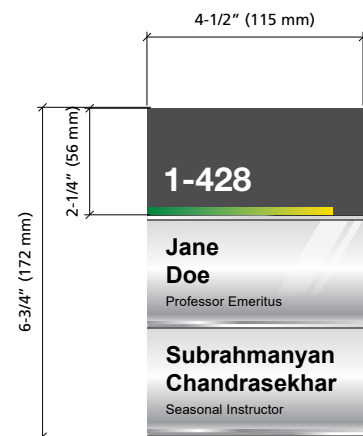

ST 1.2
Double Personnel ID, wall mount

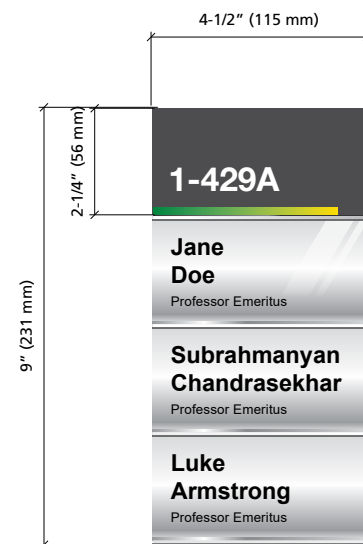

ST 1.3
Triple Personnel ID, wall mount

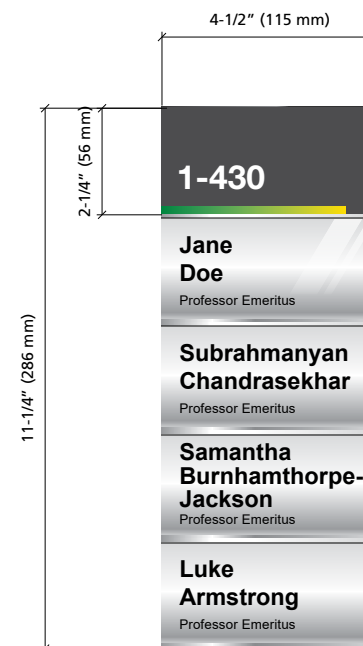

ST 1.4
Quadruple Personnel ID

Note: this sign generally intended for within an office or lab space.



Glassbackers, Adhesive
Sizes will vary pending sign type.

Colour match closest to the light grey and applied from the inside (reversed applied).

These are used to hide the back of signs.

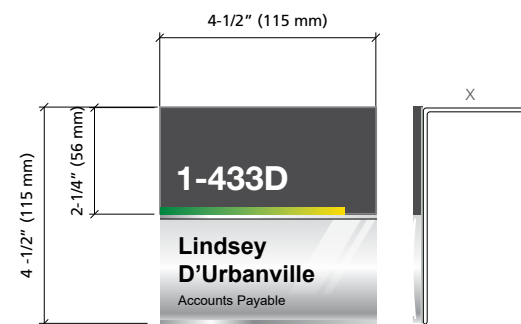

ST 1.6
Single Personnel ID, Partition / Workstation Mount

X = This dimension varies to match office screen partition in area. Specify when ordering.

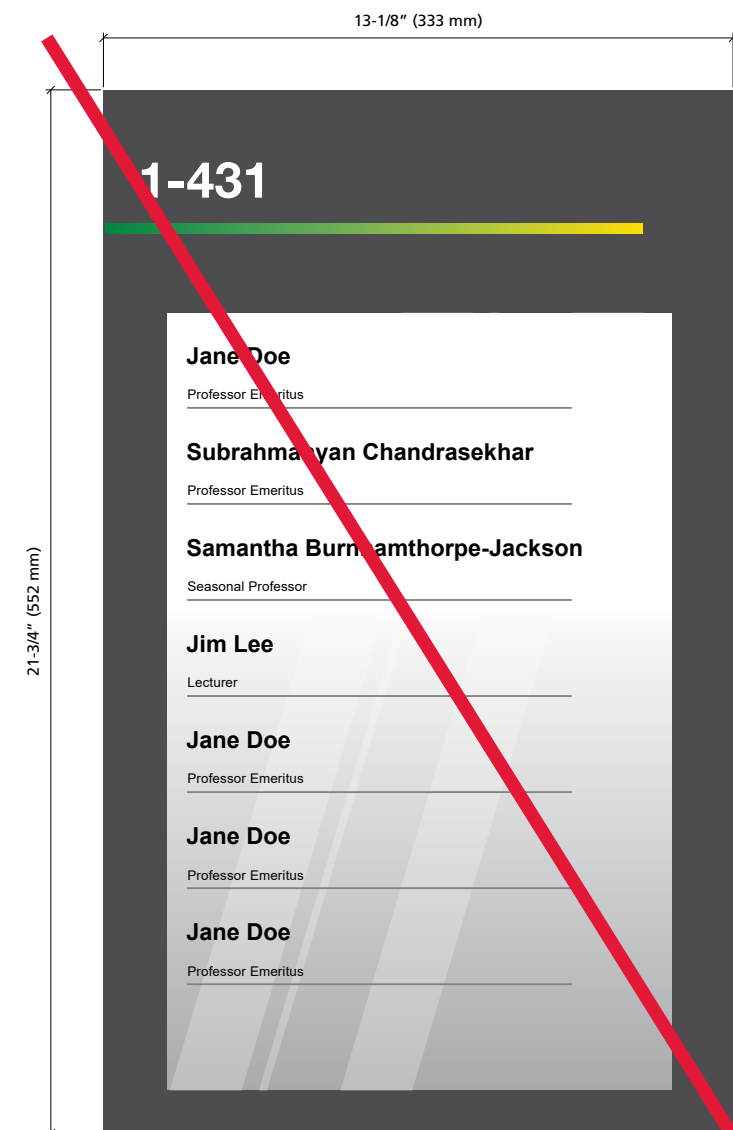

ST 1.7
Wall mount, Multi-Personnel ID (5 or more), obsolete

Note:
In practice, users have indicated a very strong preference for ST 5.6P or ST 5.6L on page 16 rather than this item.



ST 2.0 WASHROOMS, WALL MOUNTED

WHICH SYMBOL?

Originally, the combined man/woman symbol was first used with *single-stall* accessible washrooms, which were typically placed between a multi-stall men's washroom and multi-stall women's washroom. These symbols express gender in strictly binary terms, making them awkward for use in an institution that encourages inclusiveness, empathy, and understanding. Newer facilities have increasingly adopted accessibility features in their gendered multi-stall washrooms too, so effectively that they have eliminated the need for a single-stall universal washroom (from the perspective accessibility). The toilet symbol, depicted below, is meant to communicate that a washroom is available to be used by anyone, irrespective of gender expression.

Most *single-stall accessible washrooms* can migrate from the now obsolescent man/woman symbol to the non-gender specific washroom toilet symbol. However, newer facilities that have accessible multi-stall gendered washrooms but lack single-stall washrooms require careful care with symbol selection with paired with the word 'washrooms' in the plural sense. For multi-person washrooms there still needs to be clarity if the area is traditionally gendered (meaning a man or woman symbol) or universal (the toilet).

In other words, the toilet symbol should not be used to signify "men's and women's multi-stall washrooms" but intended to mean "all-gender washroom(s)." The toilet symbol should only be used if there is: (1) an all-gender single occupant washroom, or (2) an all-gender multi-occupant washroom present. It is not meant to be used to convey 'men's and women's washrooms'. Using the combined man/woman symbol in that circumstance.

Change room signs on this page use much the same methodology. A gendered figure symbol is only present to indicate a traditionally gendered change room area. All-gender or family-style change rooms use the universal change room sign. Multi-person areas like these have more features to provide privacy for all users, irrespective of gender.

Wall and door mounted signs (that are within easy reach) have tactile features (ST 2.1, 2.2, 2.3, 2.7, and 2.8) and are recommended for new capital projects, major renovations and upgrades. See page 5 for information on braille and tactile wording. When possible, avoid placing these items on doors (so that as user touching the sign is less likely to have their fingers pinched by door operation, or being startled by someone vacating the room).

Typical Grade 1 Braille Dots (see this topic on page 5) finished to match white. Braille text on these signs is for position only. Tactile letters/number finished to match white. Non-tactile (NT) signs use roman (mixed-case) typography elsewhere but rarely needed.

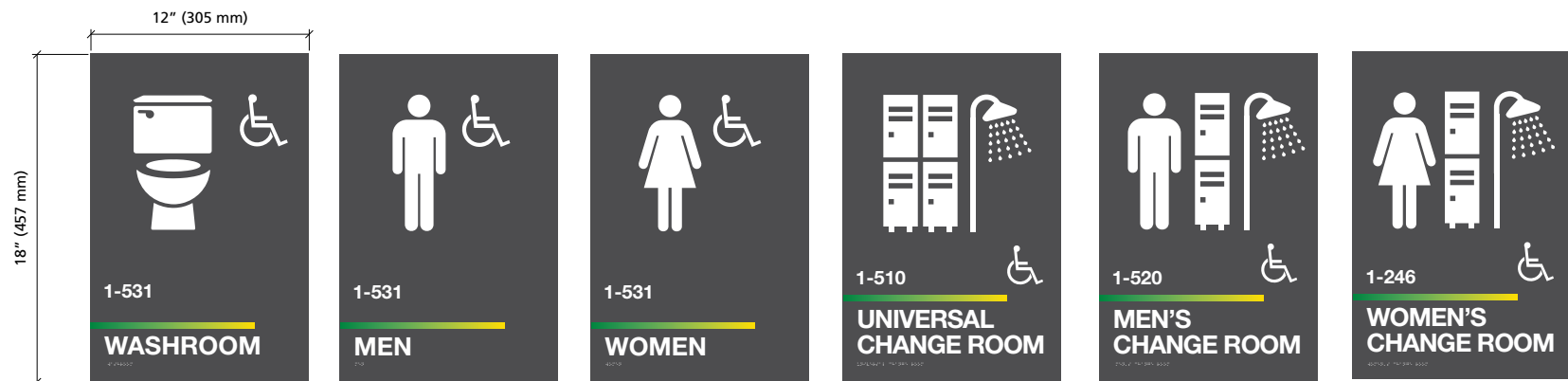

ST 2.2
Standard Medium Washroom
Numeral, Helvetica Neue 75 Bold 75 pt (0.75 inches), matte white vinyl
Raised tactile descriptor, Helvetica Neue 75 Bold 100 pt (1.00 inch), white

ST 2.2
Standard Medium Change Rooms
Numeral, Helvetica Neue 75 Bold 75 pt (0.75 inches), matte white vinyl
Raised tactile descriptor, Helvetica Neue 75 Bold 100 pt (1.00 inch), white

Backer plates (aluminum dibond) are often needed for signs on this page, as the double-sided tape and adhesives used with these signs does not stronger adhere to many of the varying wall surfaces present in washroom locations.

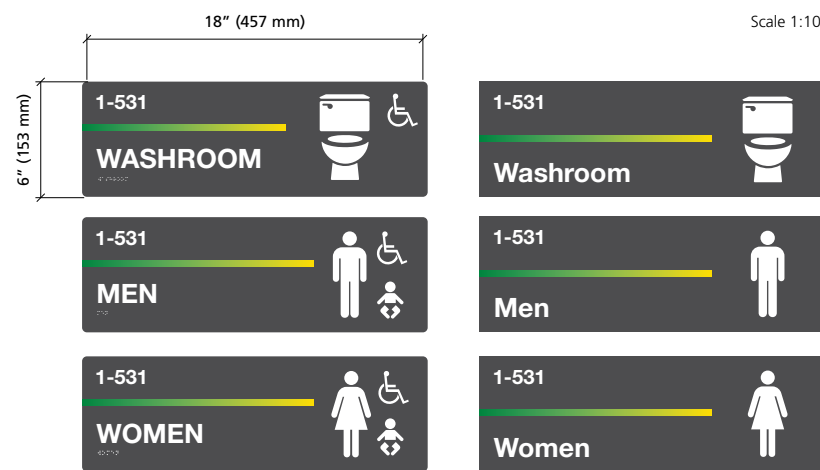
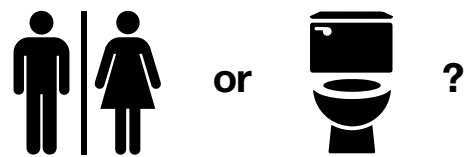

ST 2.1
Standard Washroom ID
Numeral, Helvetica Neue 75 Bold 75 pt (0.75 inches), matte white vinyl
Raised tactile descriptor, Helvetica Neue 75 Bold 100 pt (1.00 inch), white

ST 2.1 NT
Standard Washroom ID, non-tactile
Numeral, Helvetica Neue 75 Bold 75 pt (0.75 inches), matte white vinyl
Descriptor, Helvetica Neue 75 Bold 100 pt (1.00 inch), matte white vinyl

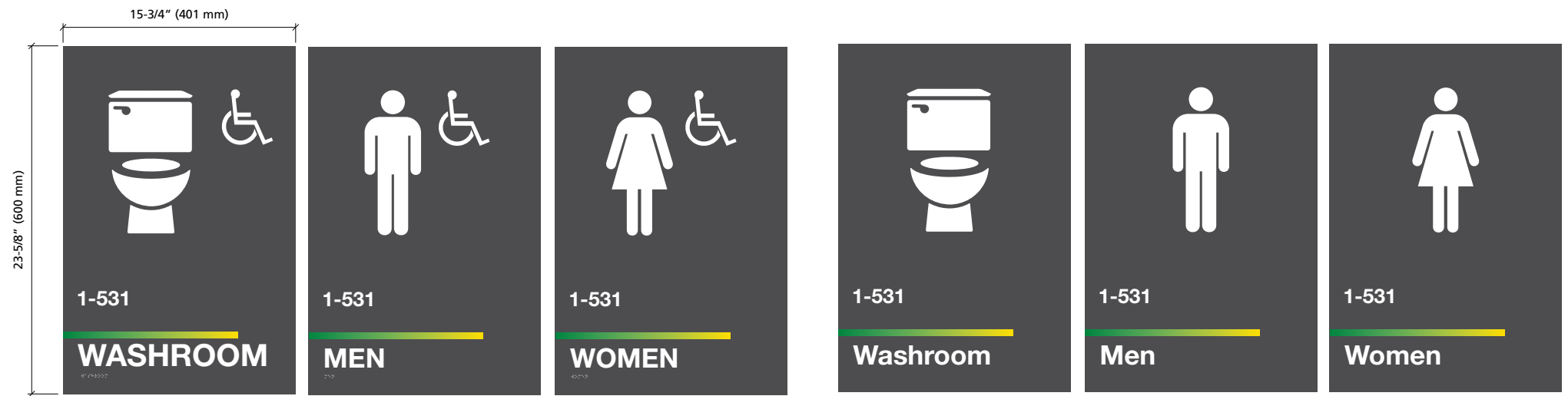

ST 2.3
Standard Large Washroom ID
Numeral, Helvetica Neue 75 Bold 100 pt (1.00 inch), matte white vinyl
Raised tactile descriptor, Helvetica Neue 75 Bold 150 pt (1.50 inches), white

ST 2.3 NT
Standard Large Washroom ID, non-tactile
Numeral, Helvetica Neue 75 Bold 100 pt (1.00 inch), matte white vinyl
Descriptor, Helvetica Neue 75 Bold 150 pt (1.50 inches), matte white vinyl

Note: NT (non-tactile) versions of sign on this page differ from their tactile equivalents in the following ways:
a) no raised applique, not braille
b) text typeset in Titlecase rather than UPPERCASE.
c) in practice, the NT variants are very rarely needed.



ST 2.4 WASHROOMS, PROJECTING

The projecting washroom signs on this page are sometimes added to supplement those on the previous page. They do not replace wall-mounted items because they cannot hope to assist those needing tactile or braille features. Consequently, these items do not repeat room numbers or include the words Washrooms, Men's, Women's, etc.

These projecting signs often require subsurface reinforcement. Even when that is provided, projecting signs are ready-made levers and usually need special mounting hardware. Refrain from their adoption within settings that might be prone to vandalism or hijinks. If used, install these signs high enough to be out of harms way.

The icon choice selected should be done to accurately reflect whether the washrooms are traditionally gendered washrooms or all-gender washrooms. Choose to use the toilet pictograph only when the washroom area offers a all-gendered option. Otherwise use man, woman, or combined man/woman symbol. See more background information on washroom symbol choice on the previous page.

The Service Elevator symbol is rarely encountered since such elevators are generally not within public areas nor intended for public use.

Scale 1:10

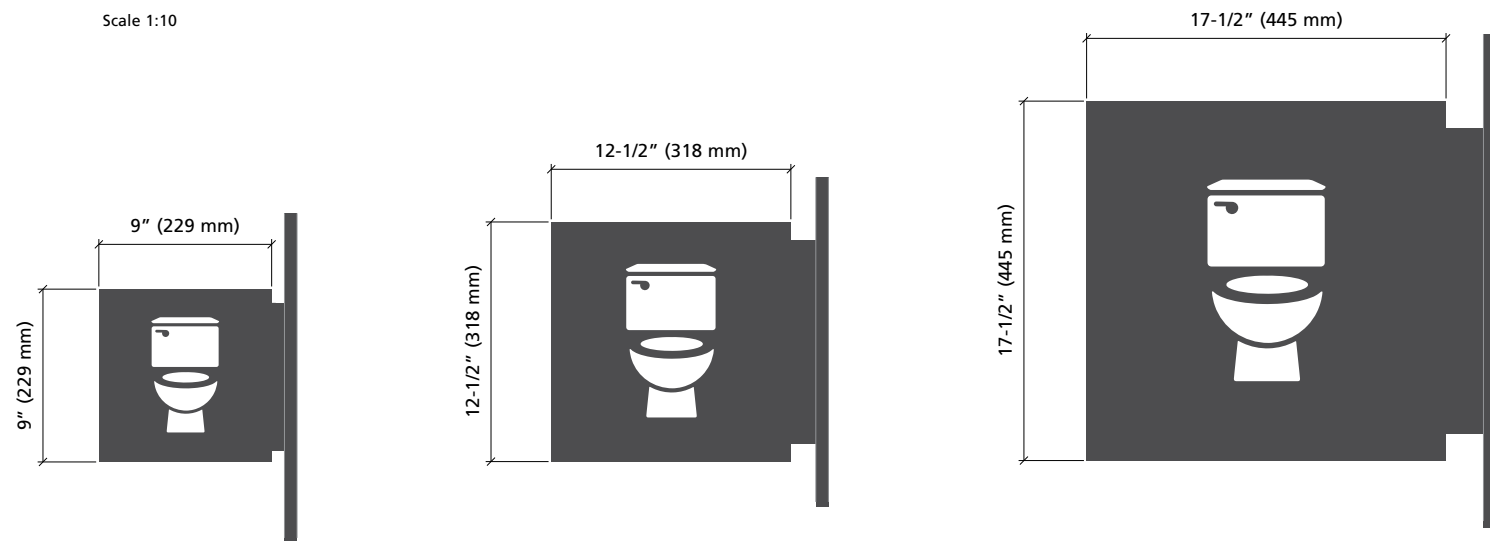

ST 2.4
Standard Base Building ID - Projecting
6" high pictogram, matte white vinyl

ST 2.5
Standard Medium Base Building ID - Projecting
8" high pictogram, matte white vinyl

ST 2.6
Standard Large Base Building ID - Projecting
10-1/2" high pictogram, matte white vinyl

Alternate Base Building Amenities:



This symbol is used when 'gender-specific washrooms' are nearby and hidden from view. The meaning of this symbol differs from the toilet only symbol.

confirm



inform



ST 2.7 & 2.8 STAIR ID & LEVEL ID

Stair Identification and Level Identification signs are primarily associated with *vertical* movement in our facilities. These items incorporate braille and tactile features, in part, because many stairwells are fire-safe-refuge areas and so that those with mobility issues have a means to specify their location to safety personnel. These signs are not intended to replace mandatory illuminated fire EXIT signs, nor 'running man' exit signs.

ST 2.7 Stair Symbol ID signs are typically placed in main circulation areas at the point of entry to a stairwell when hidden or obscured from plain view, typically by a fire-rated door. This sign is unnecessary with open stairs and only used when a stairwell is not within plain view.

ST 2.8 Floor Level ID signs are placed within stairwells to allow people to readily confirm their floor location as they move up or down the stairwell (enclosed or open). This is useful for day-to-day use, but especially for emergency circulation (when elevator use should not occur) when people are required to evacuate a building or first responders are accessing a facility. The floor level ID signs assists emergency response personnel confirm their location before entering corridors and hallways.

Wall and door mounted signs (ones within easy reach) include tactile and braille elements (ST 2.1, 2.2, 2.3, 2.7, and 2.8) and used on new capital projects or a practical upgrade if there are significant renovations or facility renewal.

These signs use typical Grade 1 Braille Dots, as per ADA requirements, finished to match white. Braille text on these signs is for position only. Tactile letters/number finished to match white.

There are instances where security or other operational restrictions may prevent free and unfettered access from a stairwell into a floor. Shown to the right are some examples of ST 2.9 signs that are meant to be paired with Stair ID or Floor level signs. These red signs and messages involve review and assessment by Emergency Management, Environmental Health & Safety, University of Alberta and harmonization with other building systems.

Scale 1:8

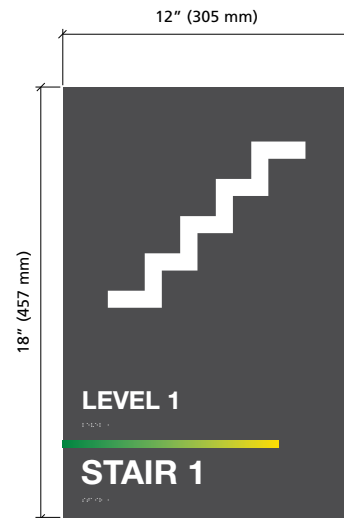

ST 2.7
Standard Stairwell ID

Raised tactile descriptor, Helvetica Neue 75 Bold 100 pt (1.00 inch), white

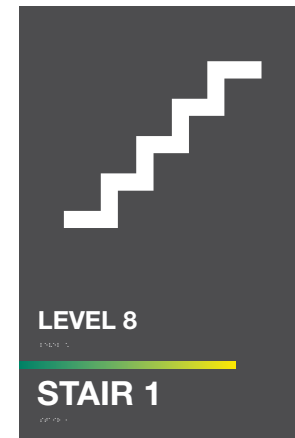

ST 2.8
Standard Level ID

Floor designator, Helvetica Neue 77 Condensed Bold 750 pt (7.50 inches), matte white vinyl

Raised tactile descriptor, Helvetica Neue 75 Bold 100 pt (1.00 inch), white

The variable message ST 2.9 signs are sized to the same width as the ST 2.7s and ST 2.8s so that they are easy to add either beneath or above the Level ID sign, as appropriate.

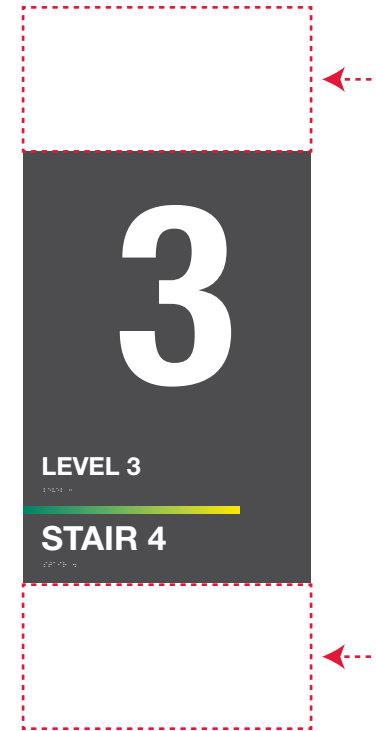

Backer plates (aluminum dibond) are often needed for signs on this page, as the double-sided tape and adhesives used with these signs does not stronger adhere to exposed concrete (often irregular) surfaces that are frequently encountered within interior egress stairwells.



ST 2.9
Door Access Information Sign

Use: For when you are in the stairwell/hallway and there is NO public access behind door.

Pairs with ST 2.7 or 2.8 depending on operation of door(s).

Header, White, Helvetica Neue 75 Bold 75 pt (0.75 inches), White

Body text, Black, Helvetica Neue 55 Roman 50 pt (0.50 inches)

Placement of these signs:
1) To sit flush below stairwell or level ID (preferable) or above.
2) When wall space is limited; placed near the door or
3) Centered on the door

Messaging may vary pending site requirements, examples:

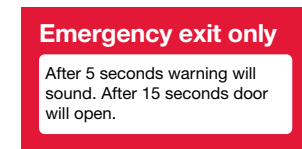
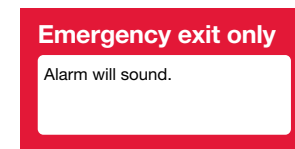

Use: For when you are in the hallway/stairwell and door is magnetically locked and alarmed.

ST 3.0 REGULATORY SIGNS

Most regulatory signs on the next few pages are related to Occupational Health and Safety or Risk Management topics. The No-Smoking decal ST 3.1 was replaced by decal ST 3.9 on the next page to better harmonize with provincial regulatory requirements for similar messages.

Accessibility 1st ST 3.4 items have been retired as underlying accessibility issues get addressed in new building design or retrofits. Items in red on this page are typically associated with fire-safety and egress-related topics and coordinated by Risk Management Services.

The CCTV decals (ST 3.3) are sometimes placed as one enters University of Alberta facilities, most typically second set of doors and after a No Smoking decal.

The Wash Hands (ST 3.10) decal are used in locker areas associated with Swimming Pool areas.

Scale 1:4

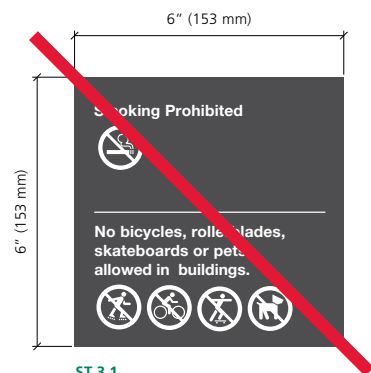

ST 3.1
Entry decal, self-adhesive
(Obsolete, too small for Provincial Regulations)
Use appropriate ST 3.9 from next page.

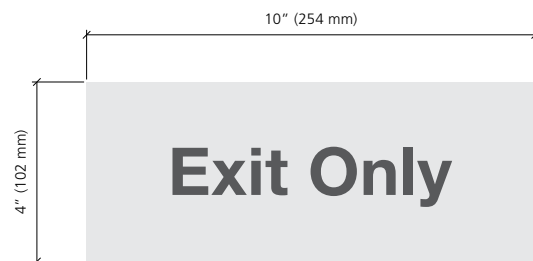

ST 3.1.1
Decal, self-adhesive
Sizes may vary due to site conditions.

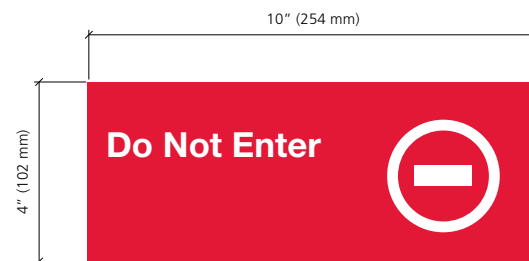

ST 3.2
Decal, self-adhesive
Sizes may vary due to site conditions.

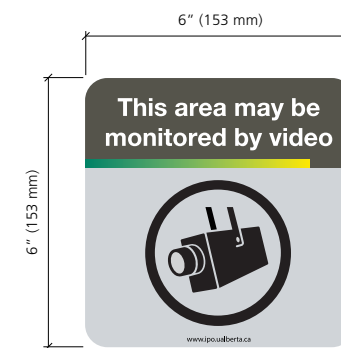

ST 3.3
CCTV decal, self-adhesive (single-sided)
For outdoor posts

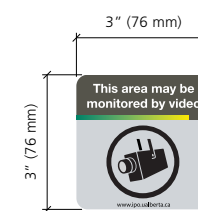

ST 3.3.1
CCTV decal, self-adhesive (double-sided)
For glass applications at entrances/vestibules



ST 3.10
Hand Washing Decal

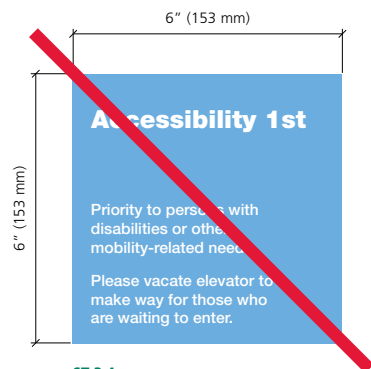

ST 3.4
Accessibility decal, self-adhesive
Superannuated



ST 3.5
Fire information decal, self-adhesive



ST 3.5.1
Fire information sign on sintra base

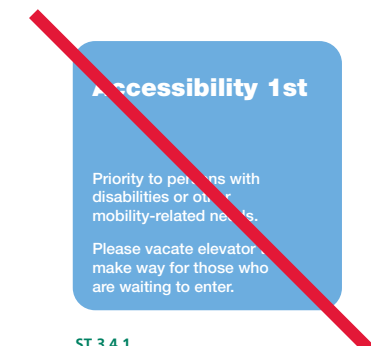

ST 3.4.1
Accessibility sign on sintra base
Superannuated



ST 3.5 Bilingual
Fire information decal, self-adhesive



ST 3.5.1 Bilingual
Fire information sign on sintra base

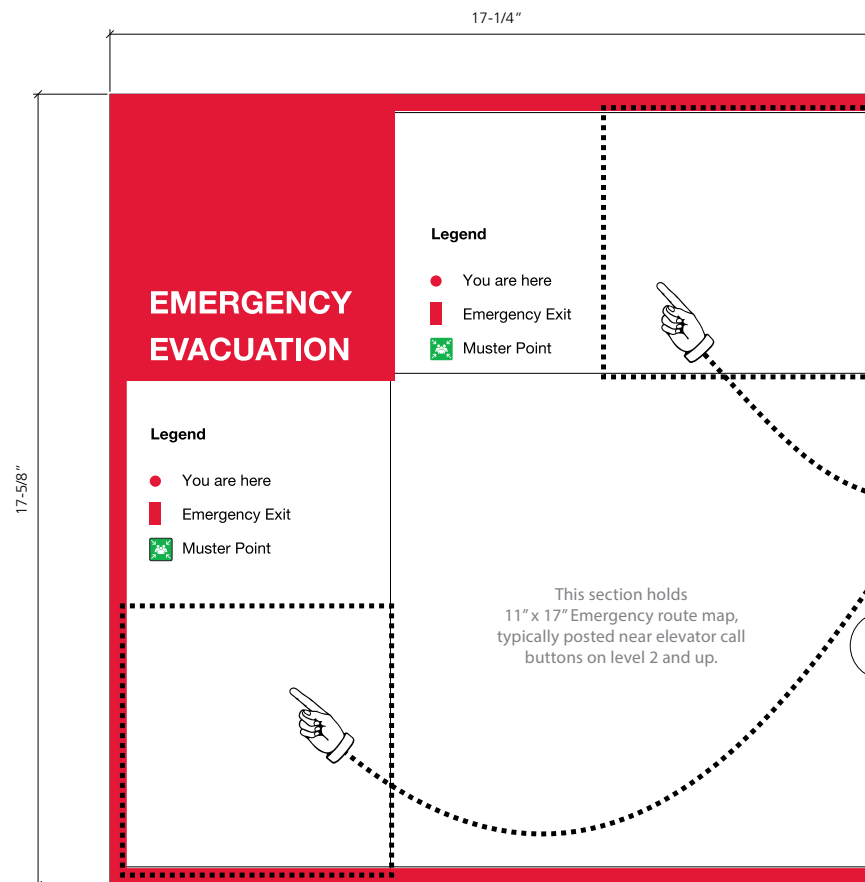

ST 3.6 Emergency Map Holder
Acrylic, Paper Updatable

Notes on ST 3.6 and ST 3.5 together

This item is typically installed as close to an elevator call-button as possible so that people do not enter elevator in the event of fire or emergency alarm. The holder contains an evacuation floorplan (not shown) that helps visitors find nearest stairwell. This item complements mandatory egress signs.

The 11x17 inch or 17x11 map is inserted into this holder (administered by Risk Management, EHS) and rotated to match the user's position. An appropriate ST 3.5 decal (below) is added to unoccupied space (either bottom left or top right corner) to remind viewer safety protocol.



ST 3.0 REGULATORY SIGNS



ST 3.7
Standard Lab ID, Updateable message,

Room numbering, matte white vinyl
Helvetica Neue 75 Bold
75 pt (0.75 inches)

Room descriptor, matte white vinyl
Helvetica Neue 75 Bold
75 pt (0.75 inches)

Information sheet 8.5" x 14" (legal size)
is updated by Risk Management and
Environmental Health and Safety.

Note: This item is also listed as a
ST 4.7 on next page. Both items are identical.
It has been intentionally double-listed in this
manual to decrease the chances that it is
overlooked by those doing minor renovations.

Our wet laboratories (those with sinks and chemicals) typically consolidate the room number, room description, and related hazard and safety information within one sign. The hazard information is a legal-sized paper insert prepared by EHS and the lab occupants. In an emergency, first-responders can better anticipate lab hazards and find contact information for the lab operator.

To post your hazard insert:

1. Register in the EHS database

To register your research group in the EHS database, e-mail ehs.info@ualberta.ca.

2. Print your hazard signage

If your group is currently in the database, you can print your own hazard signage. Follow the instructions in the applicant manual to print signage. Hazard signage should be printed in colour. If your group does not have access to a colour printer, contact us at ehs.info@ualberta.ca and EHS will print a colour sign for your group.

3. Update a hazard sign

Information on your hazard signage should be kept current. Once you have amended the information in the database, print new signage as soon as possible.

The most current information is this topic is available at:

<https://www.ualberta.ca/environment-health-safety/hazard-management/how-can-i-control-them/administrative-controls/ehs-database>

<https://www.ualberta.ca/environment-health-safety/lab-safety-and-management/set-up-a-lab/post-hazard-signage>



ST 3.9 North/South Campus
Exterior No Smoking Sign/Decal w/ QA contact number. Item is two-sided with the adhesive design on back flipped to minimize show-through.



ST 3.9 Augustana
Augustana version using 679-1618 maintenance number.



ST 3.9 Campus Saint-Jean
French version.

Note: In 2018, the distance was changed from 5 metres to 10 metres (by using a small cover-up decal over the bottom portion of these decals).

These No Smoking signs supercede obsolete ST 3.1 (see page 10), as provincial regulation requires these items be sized 8.5 x 11.

The 10m restriction was changed from 5m in 2018 at about the same time as the introduction of legalized cannabis.

The No Smoking symbol is understood to apply to include tobacco, cannabis, and vaping products.

To minimize visual clutter and consolidate information, this item also includes other common facility restrictions and a maintenance number appropriate to appropriate campus (North/South Campus, Augustana, and a french-language version for Campus Saint-Jean).

These items are typically double-sided, allowing it to be placed on glass or solid surfaces. One's applied to glass remind both those entering a building or those leaving a building for their smoke-break. When placed on glass, strive to place it on the interior side of the glass so that it is protected from the weather. Tinted glass may require application of this item twice, however.



ST 4.0 ROOM ID ACADEMIC, ADMINISTRATIVE

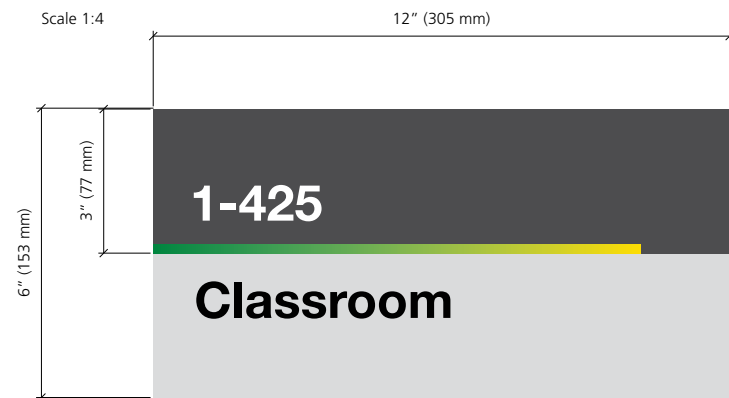

ST 4.1
Standard Classroom ID

Room numbering, matte white vinyl
Helvetica Neue 75 Bold
75 pt (0.75 inches)

Room descriptor, matte black vinyl
Helvetica Neue 75 Bold
75 pt (0.75 inches)

Note:
Office of Registrar prefers
ST 5.7 sign for centrally scheduled
classrooms. The ST 5.7 includes a paper
changeable portion, convenient for
them to post information in the event
of class relocation.

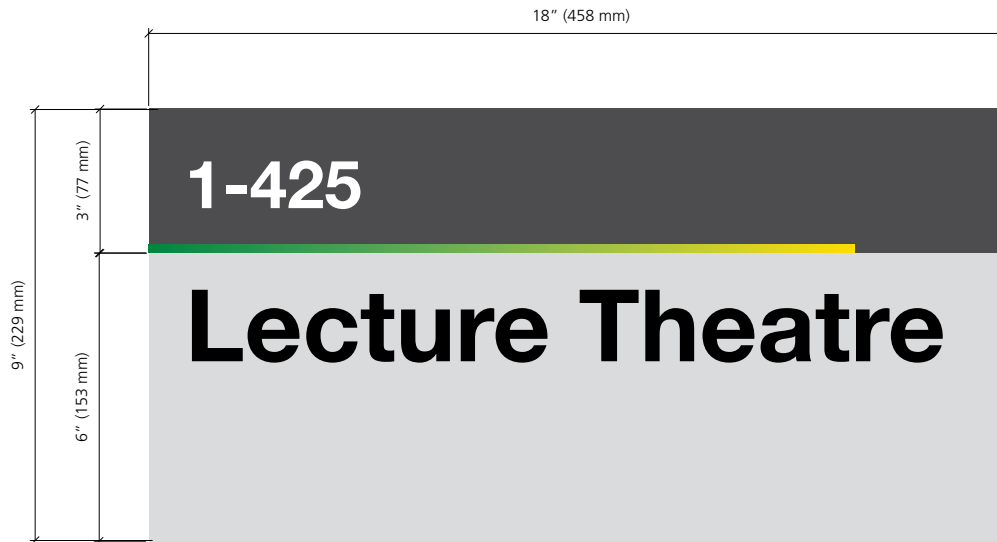

ST 4.2
Standard Large Classroom ID

Room numbering, matte white vinyl
Helvetica Neue 75 Bold
100 pt (1.00 inch)

Room descriptor, matte black vinyl
Helvetica Neue 75 Bold
150 pt (1.50 inches)

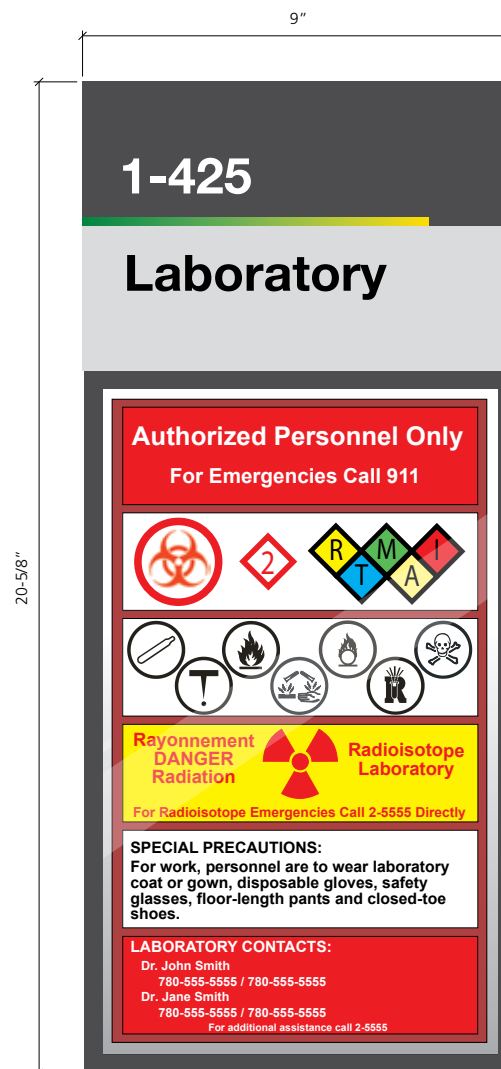

ST 4.7
Standard Lab ID, Updateable message,

Room numbering, matte white vinyl
Helvetica Neue 75 Bold
75 pt (0.75 inches)

Room descriptor, matte white vinyl
Helvetica Neue 75 Bold
75 pt (0.75 inches)

Note: This item is also listed as a
ST 3.7 on next page. Both items are identical.
This sign has been intentionally double-listed in this
manual to decrease the chances that it is
overlooked by those doing minor renovations.
Insert details on previous page.

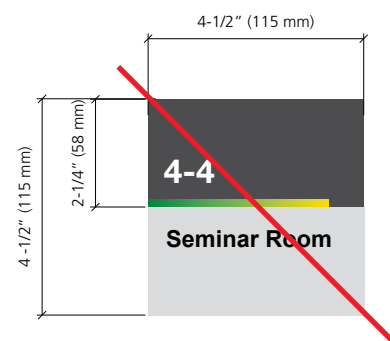

ST 4.3
Standard Office Room ID

Room numbering, matte white vinyl
Helvetica Neue 75 Bold
50 pt (0.50 inches)
Room descriptor, matte black vinyl
Helvetica Neue 75 Bold
35 pt (0.35 inches)

Note: Discontinued
Use ST 1.1 instead

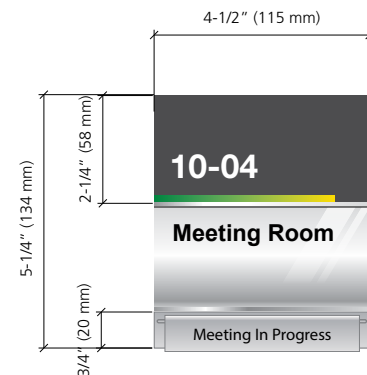

ST 4.4
Standard Meeting Room ID

Room numbering, matte white vinyl
Helvetica Neue 75 Bold
50 pt (0.5 inches)

In-house Updatable paper Room descriptor
Arial 75 Bold
35 pt (0.35 inches)

See specifications on ST 1.1 for electronic
template information.

Meeting In Progress, matte black vinyl
Helvetica Neue 75 Bold
25 pt (0.25 inches)

Note: In practice, ST 1.1 or ST 5.6 more
commonly used, as users who vacate room
typically overlook resetting the bottom
component to 'Vacant' or 'Available.' This
item is sometimes useful when a larger
conference room has a secondary access
for catering staff.

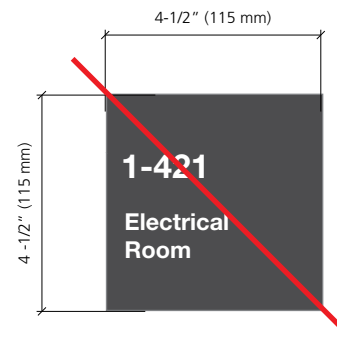

ST 4.5
Standard Back of House Room ID
(sintra panel)

Room numbering, matte white vinyl
Helvetica Neue 75 Bold
50 pt (0.5 inches)
Room descriptor, matte white vinyl
Helvetica Neue 75 Bold
35 pt (0.35 inches)

Note: Discontinued
Use ST 1.1 instead

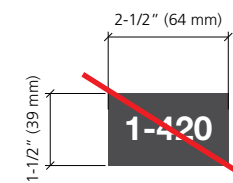

ST 4.6
Standard Room Number Only (sintra panel)
Room numbering, matte white vinyl
Helvetica Neue 75 Bold
50 pt (0.5 inches)

Note: Discontinued
Use ST 1.1 instead



Glassbackers, Adhesive
Sizes will vary pending sign
type.

Colour match closest to the
light grey and applied from the
inside (reversed applied).

These are used to hide the back
of signs.



ST 4.8 ROOM ID STUDENT RESIDENCES

Most signs shown elsewhere in this signage manual are primarily for academic, research, or classroom settings. Our residences and some special clean laboratories use vinyl or painted-on identification signs because there is a need to simplify cleaning and maintenance, discourage vandalism, and eliminate dust and particle traps that could contaminate or affect research.

SUITE EVACUATION DECALS

Within Student Residence suites, an evacuation decal (similar to above) is added near the door peephole within the suite. The left side, in red, is general safety information. Also see ST 3.6 Emergency Map Holder for a related item posted near elevators. The right side is a simplified floor plan (always oriented to match the occupant's perspective) that includes:

1. Official building name
2. Level
3. Room / Suite Number
4. "You Are Here" button
5. Recommended fire-safe stairwells on that floor, coloured in red
6. Approximate exterior muster-point locations.

The presence of this item is to help teach local emergency protocols to our students, especially international students (who may be unfamiliar with local processes). Additionally, these decals are helpful during the summer when suites might be repurposed for non-residence use activities like hosting guest conferences, researcher hosting, athlete hosting, or other outreach activities.

Decal content is typically completed during initial building fit-out and done with collaboration between Risk Management Services, EH&S and Space Planning & Inventory Services (SPIS).

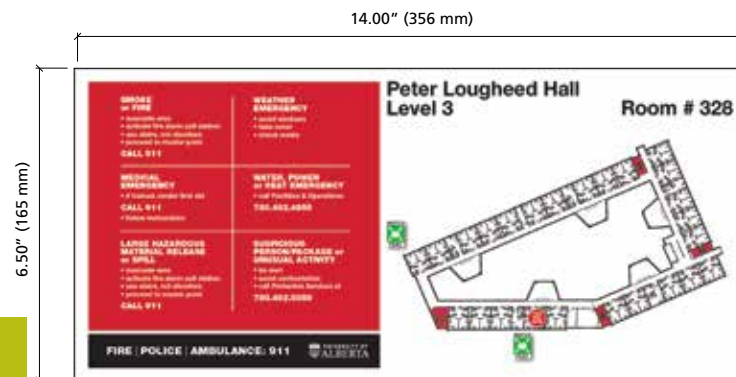

Residence Suite Evac Decal
Decal specifications: Finished size: 4.0 X 6.5"; Colour: CMYK 4/0 no bleeds; adhesive backed (non-repositionable); Stock: 60lb Mohawk Specialty Digital Label Permanent

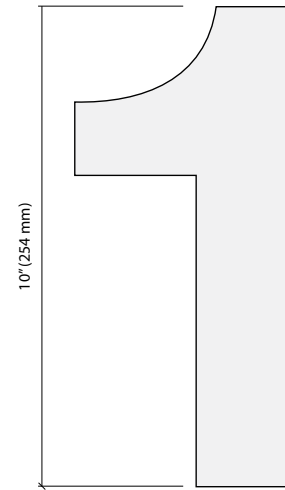

ST 4.11
Large Room Number, Vinyl Reflective (outdoor)
Cut Out on Reflective White Vinyl Helvetica Neue 75 bold 1000 pt (10.0 inches)
Typically used for identifying Shipping/Receiving Bay Doors, Garbage/Recycling Doors

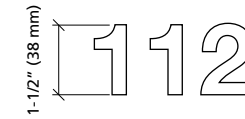

ST 4.12
Small Room Number, Vinyl Reflective (outdoor)
Cut Out on Reflective White Vinyl Helvetica Neue 75 bold 150 pt (1.5 inches)
Typically used for identifying exterior back of house doors



ST 4.10
Room Name and Number Non-Reflective (indoor)
White Matte Vinyl Helvetica Neue 75 bold 200 pt (2 inches)

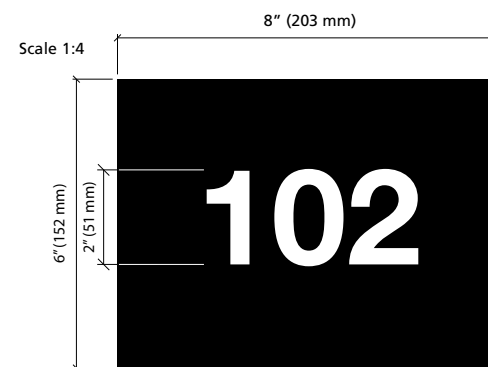

ST 4.8
Room Number, Vinyl Stencil Non-Reflective (indoor)
Knock / Cut Out on Paint Mask Vinyl Numeral, painted black or white to contrast with door colour Helvetica Neue 75 bold 200 pt (2.0 inches)
Temporary Painter's Mask for Stencil Door Room Numbers

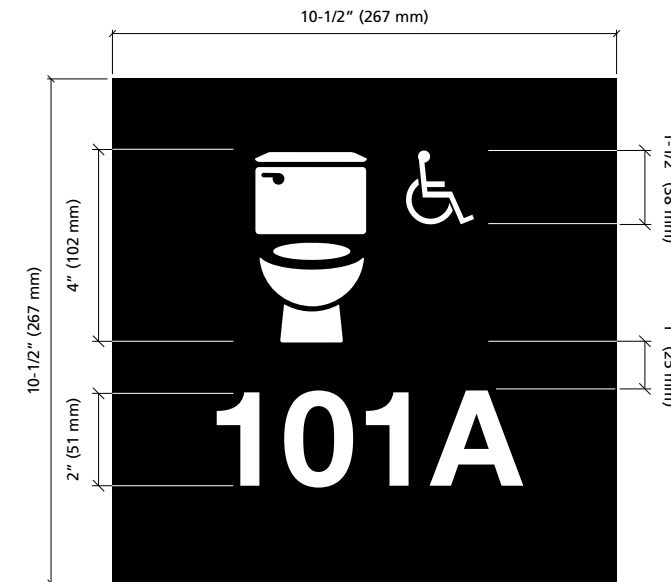

ST 4.9
Room Number with Pictogram, Vinyl Stencil Non-Reflective (indoor)
Knock / Cut Out on Paint Mask Vinyl Numeral, painted black or white to contrast with door colour Helvetica Neue 75 bold 200 pt (2 inches) Pictogram 4 inches in height

Procedure for painting associated with stencils ST 4.8 and ST 4.9

1. Apply stencil on clean and dry surface.
2. Using a hard rubber roller or seam roller, firmly press all stencil edges that will be painted onto the surface.
3. For smooth surfaces, apply one coat of clear waterborne epox (Benjamin Moore Corotech Waterborne Amine Epoxy V440) using a 5mm non-shed touch up roller. Do not apply too heavily. If there is a substantial amount of orange peel on the surface to be painted, apply a second coat of epoxy after 8 hours but no later than 48 hours.
4. Apply first paint coat, using a 5mm non-shed touch up roller after 8 hours but no later than 48 hours. Apply second coat of paint for coverage if required, once first coat is dry. Recommended product is Benjamin Moore e Advance Waterborne Interior Alkyd Pearl K792. This is available in all Benjamin Moore colours.
5. For extra durability, a coat of Benjamin Moore Stays Clear Acrylic Polyurethane Low Lustre K423 can be applied.
6. Carefully remove stencil once top coat is dry. Use a sharp utility knife to lift unconnected stencil parts from the surface.



ST 5.0 INFORMATION SIGNS

In some instances, areas need to post non-regulatory information near the point of entry into an area. This page covers most examples.

Administrative areas tend to favour ST 5.6 for posting their unit names and their hours of operation. This sign is also favoured for conference or meeting rooms when staff need to post a daily or weekly meeting schedule.

The ST 5.7 is associated with larger classrooms and includes a paper changeable component favoured by Office of the Registrar (responsible for classroom scheduling) as it allows them to post classroom relocation information on short notice.

The ST 5.8/8.6 tends to be favoured in Library settings where a map insert can be updated to show call numbers, book stacks, and locations of elevators, check-out area, and washrooms.

The freestanding ST 5.11 (or similar items) is sometimes used for short-term events like concerts, gatherings, or for special announcements, and then put away after use. This item is generally discouraged for anything but temporary use because it: obstructs student movement between classes; is a potential tripping hazard for those with mobility disabilities; and tends to obstruct floor cleaning equipment.

Scale 1:10

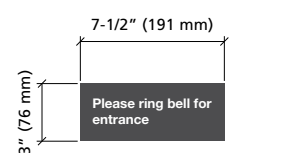

ST 5.1
Small messaging

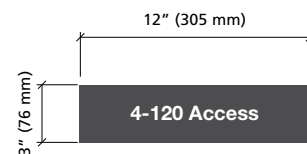

ST 5.1.1
Small messaging

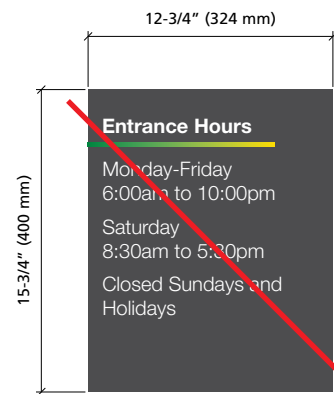

ST 5.4
Medium permanent messaging
Discontinued, see ST 5.6 if needed.

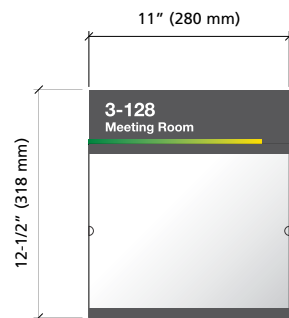

ST 5.6L (landscape)
Updateable message, letter size
Thumb notches on face

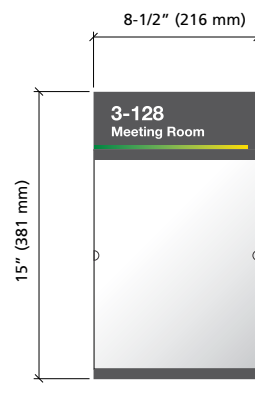

ST 5.6P (portrait)
Updateable message, letter size
Thumb notches on face

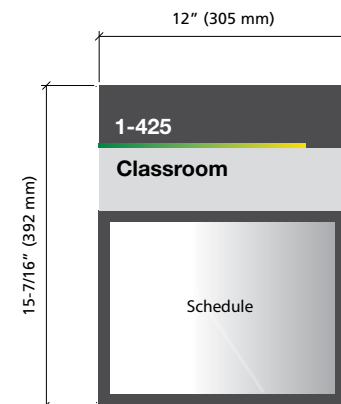

ST 5.7
Updateable message, letter size, landscape

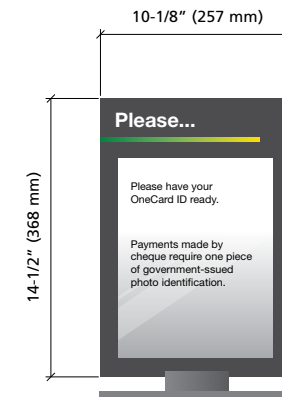

ST 5.10
Updateable message, letter size, vertical desk stand

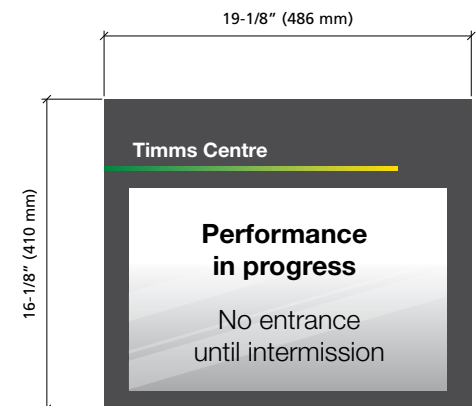

ST 5.11
Updateable message, tabloid, freestanding

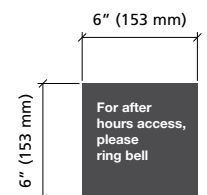

ST 5.2
Medium messaging

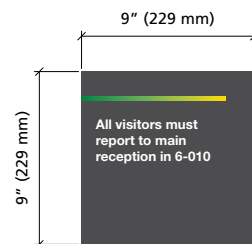

ST 5.3
Large messaging

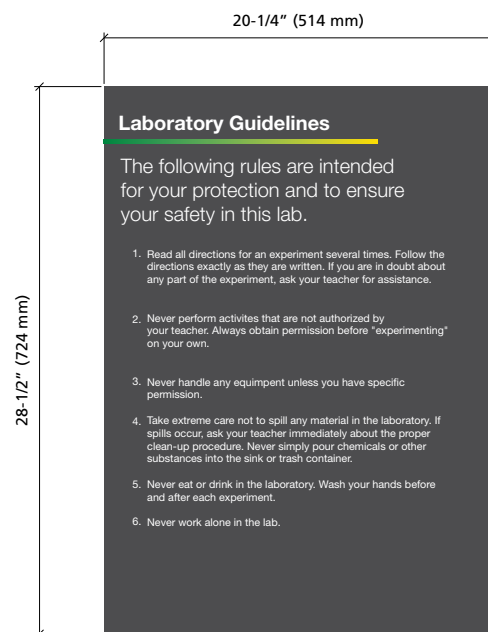

ST 5.5
Large permanent messaging
Rarely practical, consider alternates ST 3.7, ST 5.6

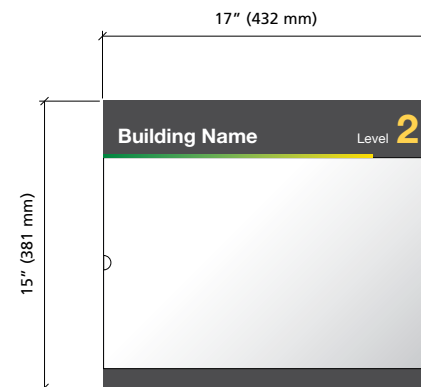

ST 5.8L/8.6L
Map Holder, tabloid size (landscape)

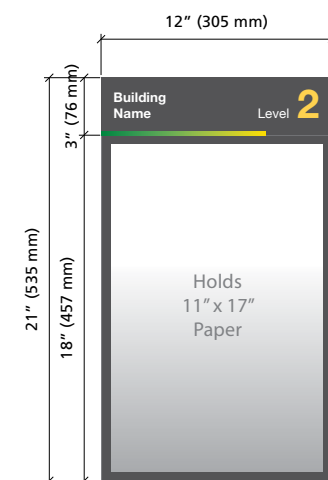

ST 5.8P/8.6P
Map Holder, tabloid size (portrait)

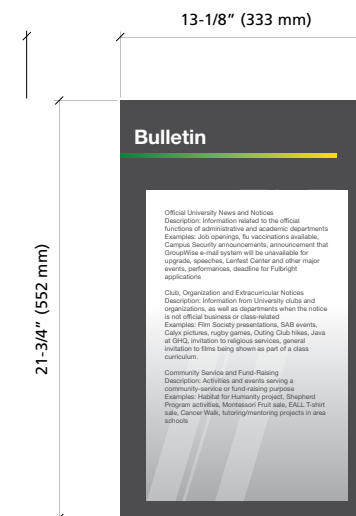

ST 5.9
Updateable message, tabloid size



ST 6.0 DIRECTIONAL SIGNS

Directional signs point people to room numbers (usually classrooms), amenities (like washrooms, elevators) and key administrative areas (ones intended to be directly accessed by the public). Stairs and exit information are not included on these signs – so that they could not contradict emergency egress signs ('red exit' and 'green running man symbol' signs). Signs are typeset in English on our campuses, except for those at our French immersion setting at Campus Saint-Jean.

These signs strive to be succinct and direct. Long and cumbersome names may be shortened to meaningful keywords, and acronyms may be used for reasons of space.

White or black text is used for features/destinations that are within the immediate setting and limited to destinations on that particular floor – this is so that those with mobility issues are as able to use the signs to find destinations as those who are able-bodied. Thus, navigation first stresses internal vertical movement (usually via elevators/stairs) before considering secondary horizontal movement on a given floor. The yellow text on some pointer signs is to highlight major facilities that are nearby but not within the immediate building and can be reached by an interior hallway or pedway. Thus, yellow lettering on an interior sign typically points to an immediately adjacent building.

The placement of text and arrows on the sign is done to reinforce, from the perspective of the viewer, the intended direction of travel. Thus, destinations to one's left are

placed on the left side of sign and designations to one's right are placed on the right side of the sign. Destinations that are straight ahead (forward) strive to be at the top of the sign. Arrows on the sign are sized to match their lettering. When phrases are long and broken onto two or more lines, the arrow is placed ahead of the phrase if the phrase is on the left side. If the phrase is on the right side of the sign, the arrow is placed at the end of the phrase.

Visual spaces (or breaks in the sign) are used to group information by travel direction and to make the sign visually easier to process. Alphabetical order may or may not be applicable depending on context and circumstances. The sign layout is optimized for the anticipated needs of the first-time visitor, typically favouring the needs of a student seeking a classroom destination.

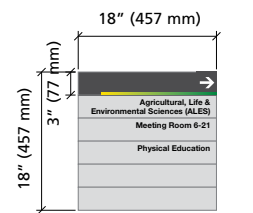

ST 6.1
Wall mount directional

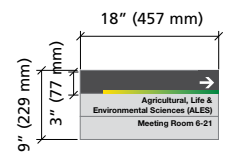

ST 6.2
Wall mount directional

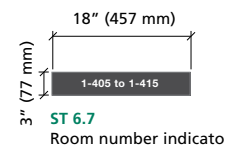

ST 6.7
Room number indicator

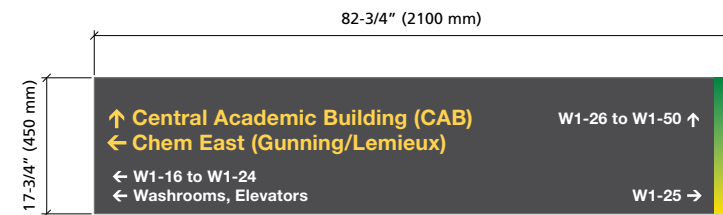

ST 6.12
Wall mount directional

ST 6.13
Suspended directional

Scale 1:25

Primrose yellow vinyl, 2" high arrow and intra-building information
Helvetica Neue 75 Bold 200 pt (2.00 inches)

Matte white vinyl, 1-1/2" high arrow and intra-building information
Helvetica Neue 75 Bold 150 pt (1.50 inches)

Left arrows placed on left side of sign, text flush left

Right arrows on right side, text flush right ahead arrows may be set to either with preference towards top of sign

Note: Text smaller than 150 pt not appropriate for very low ceiling or confined areas with short view

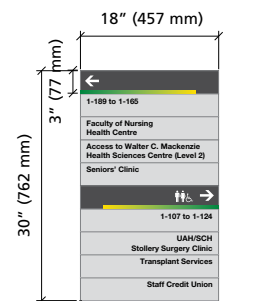

ST 6.3
Wall mount directional

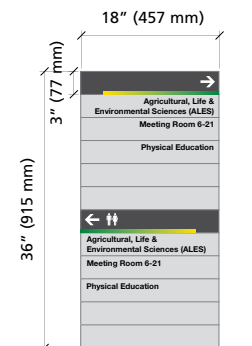

ST 6.4
Wall mount directional

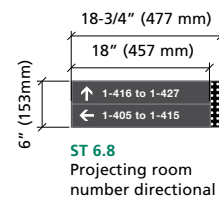

ST 6.8
Projecting room number directional

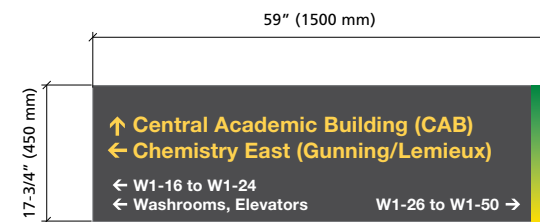

ST 6.14
Wall mount directional

ST 6.15
Suspended directional

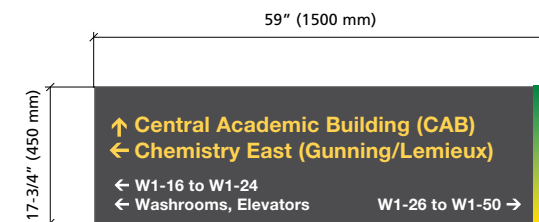

ST 6.16
Projecting directional

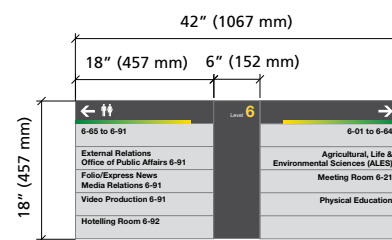

ST 6.5
Elevator lobby directional sign

Dark grey header, 1-1/2" arrows and icons, matte white vinyl

Matte black text set flush right or flush left to reinforce direction of travel, Helvetica Neue 75 Bold 75 pt (0.75 inches)

Also, recommend top line indicate generic room range.

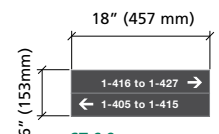

ST 6.9
Wall-mount room number directional

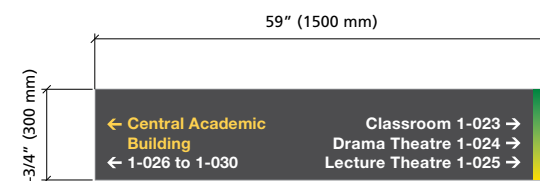

ST 6.17
Wall mount directional

ST 6.18
Suspended directional

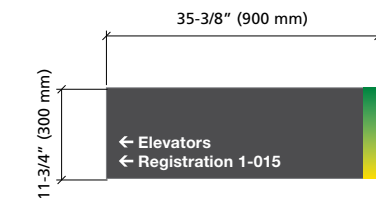

ST 6.19
Wall mount directional

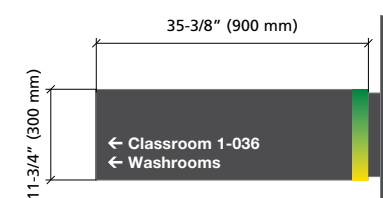

ST 6.21
Projecting directional

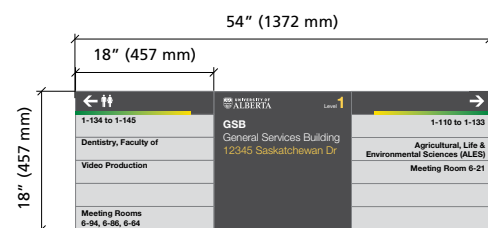

ST 6.6
Secondary building access directional

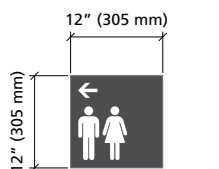

ST 6.10
Medium Directional

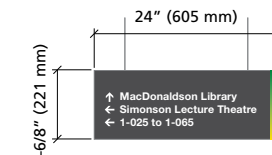

ST 6.22
Small directional suspended

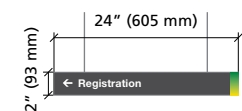

ST 6.23
Single destination suspended

Matte white vinyl, Helvetica Neue 75 Bold 100 pt (1.00 inch)

Left arrows placed on left side of sign, text flush left

Right arrows on right side, text flush right ahead arrows may be set to either with preference towards top of sign

Note: Text smaller than 150 pt not appropriate for sign unless very low ceiling or confined areas with short viewing distance.

Note: Projecting signs ST 6.21 and ST 6.16 are used as a last resort -- only when equivalently sized Wall or Suspended signs can't be used because of site conditions. These projecting signs are avoided because they are less long-lasting than their wall mounted or suspended variants.



ST 7.0 LARGE GOAL ID

This page has examples of larger goal signs that may be needed to replace or supplement smaller ST 1.0 signs (page 6) or ST 4.0 signs (page 12). Like those signs, these are meant to help a viewer confirm their final destination. In some instances faculty or departmental logos may be present instead, so also see ST 9.0 (page 9) within the Identity section. Note that goal identification should incorporate a room number as part of identification, as in these samples below.

Scale 1:20

Legacy Room

John A. Weir Memorial Law Library

ST 7.1
Fabricated, brushed aluminum-finished, dimensional lettering, usually donor lettering.
Sizing and placement in accordance with Advancement Naming Opportunity Plan.

ST 7.1.1
Fabricated, paint-finished dimensional lettering, generally donor lettering, custom lettering

ST 7.2
Wall-mount goal sign

Numeral, matte white vinyl
Helvetica Neue 75 Bold
75 pt (0.75 inches)

Text, matte white vinyl
Helvetica Neue 75 Bold
100 pt (1.00 inch)

Helvetica Neue 45 Light
75 pt (0.75 inches)

ST 7.4
Bulkhead-mount goal sign

1-429

Faculty of Extension
Adult and Continuing Education

ST 7.5
Suspended goal sign

1-430 to 1-480

School of Business - AMIS
Accounting & Management Information System

Numeral, matte white vinyl
Helvetica Neue 75 Bold
150 pt (1.50 inches)

Goal text, matte white vinyl
Helvetica Neue 75 Bold
200 pt (2.00 inches)

Helvetica Neue 45 Light
200 pt (2.00 inches)

ST 7.3
Secondary wall-mount goal sign

1-428

Office to the Assistant to the Dean

ST 7.6
Secondary wall-mount goal sign

1-428

Office of the Dean
Faculty of Arts

ST 7.6.1
Secondary suspended goal sign

Numeral, matte white vinyl
Helvetica Neue 75 Bold 150 pt (1.50 inches)

Goal text, matte white vinyl
Helvetica Neue 75 Bold 200 pt (2.00 inches)

Helvetica Neue 45 Light 200 pt (2.00 inches)

ST 7.7
Tertiary wall-mount goal sign

1-427

Lecture Theatre

ST 7.7.1
Tertiary suspended goal sign

Numeral, matte white vinyl
Helvetica Neue 75 Bold 150 pt (1.50 inches)

Goal text, matte white vinyl
Helvetica Neue 75 Bold 200 pt (2.00 inches)

Front (Outside) Elevation

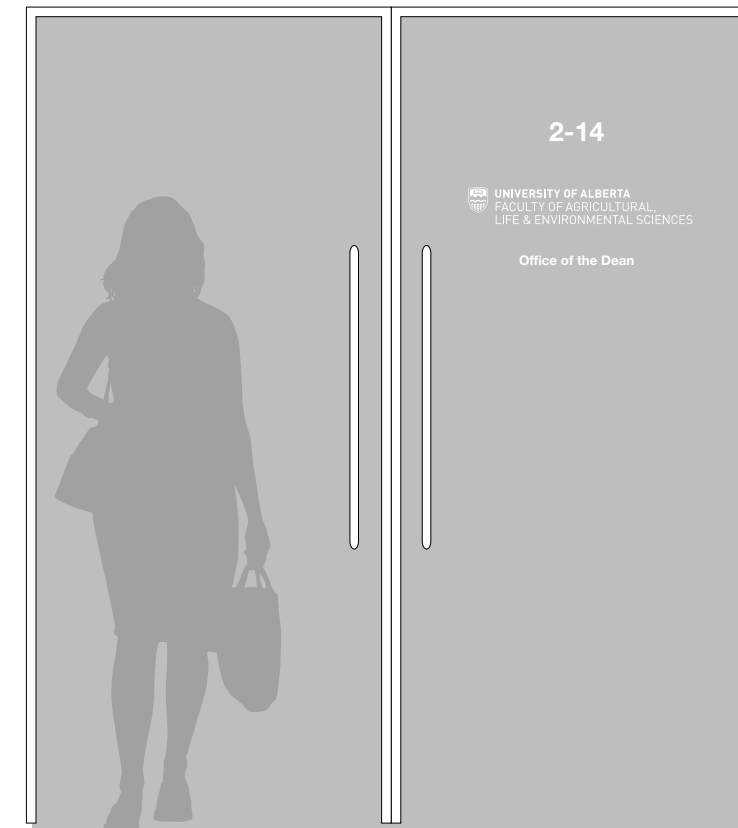

ST 7.8 Window Vinyl (example)

Door-applied vinyl graphics (example)

Right-reading (front side of door), matte white or matte black vinyl. Position may be adjusted to suit different door styles and architecture. Pinstripes does not apply to glass application.
Numeral: 200 pt / 2.00 inch Helvetica Numeral

Faculty/Department Logo (varies), premask area about 24.00 x 8.00 inch (typically). All official logos are distributed by Marketing & Communications. Supplemental admin name (not present in logo): 100pt = 1.00 inch. or 150pt, 200pt, etc.

Electively, to improve legibility, one sometimes adds: Wrong-reading (back-side of glass), or etch-glass vinyl

ST 8.0 DIRECTORIES & SUB-DIRECTORIES

DIRECTORY CONTENT BASICS

The primary role of any directory is to inform or provide an overview of the environment the visitor is in. A visitor usually has some sort of keyword as information to use. In our academic settings, this keyword is usually a proper noun, typically a department name or a basic service, (i.e.: 'Undergraduate Services', 'Observatory', 'West Pool'). All things on a directory should be things that the viewer is encouraged to access *unaided*. Directories prioritize information that is core to day-to-day operations and typically omit information that is not relevant. Washrooms, lounges, lobbies, specific food or retail kiosks, and vending areas are thus not listed.

Comprehensive directories (ones that provide building-wide information) tend to be placed at main entry points, usually on the ground floor access area, or level 2 if there is significant pedway access. Levels 3 and above tend to be smaller floorspace and those sub-directories only detail items on their respective floor (a visitor this far into a building has already bypassed a main directory). Upper floor sub-directories have little content and sometimes unnecessary.

Information included on a directory is more helpful if it is organized like the index of a book – ideally alphabetical and sorted by keyword. Building-wide directories that are ordered to resemble an organizational chart – or organized by floor occupancy – are not as helpful because the visitor is unlikely to know how to find their topic. A directory is *never* intended to list all of a given building's contents, just the areas the visitor is encouraged to access independently. Anything the user cannot access should not be listed nor shown on a directory or its maps. Floor subdirectories should take care to include information only relevant to their respective floor.

Classrooms and Lecture Theatres are typically not listed on directories because a student's timetable indicates classroom locations as a by-product of their course schedule. Any single classroom may host many different courses. Named classrooms and Lecture Theatre terminology does not appear in a student's course transcript (Beartracks) – and thus does not drive classroom wayfinding. In practice, named classrooms or a named lecture theatre is language that appears on goal signs, but rarely practical or purposeful as language for wayfinding signage.

If a map is present on a directory, it should only depict basic areas: washrooms, stairs, elevators, generic room numbering, and key destinations. Research or utility facilities with restricted access, or facilities with very limited numbers of visitors do not need directories or visitor maps.

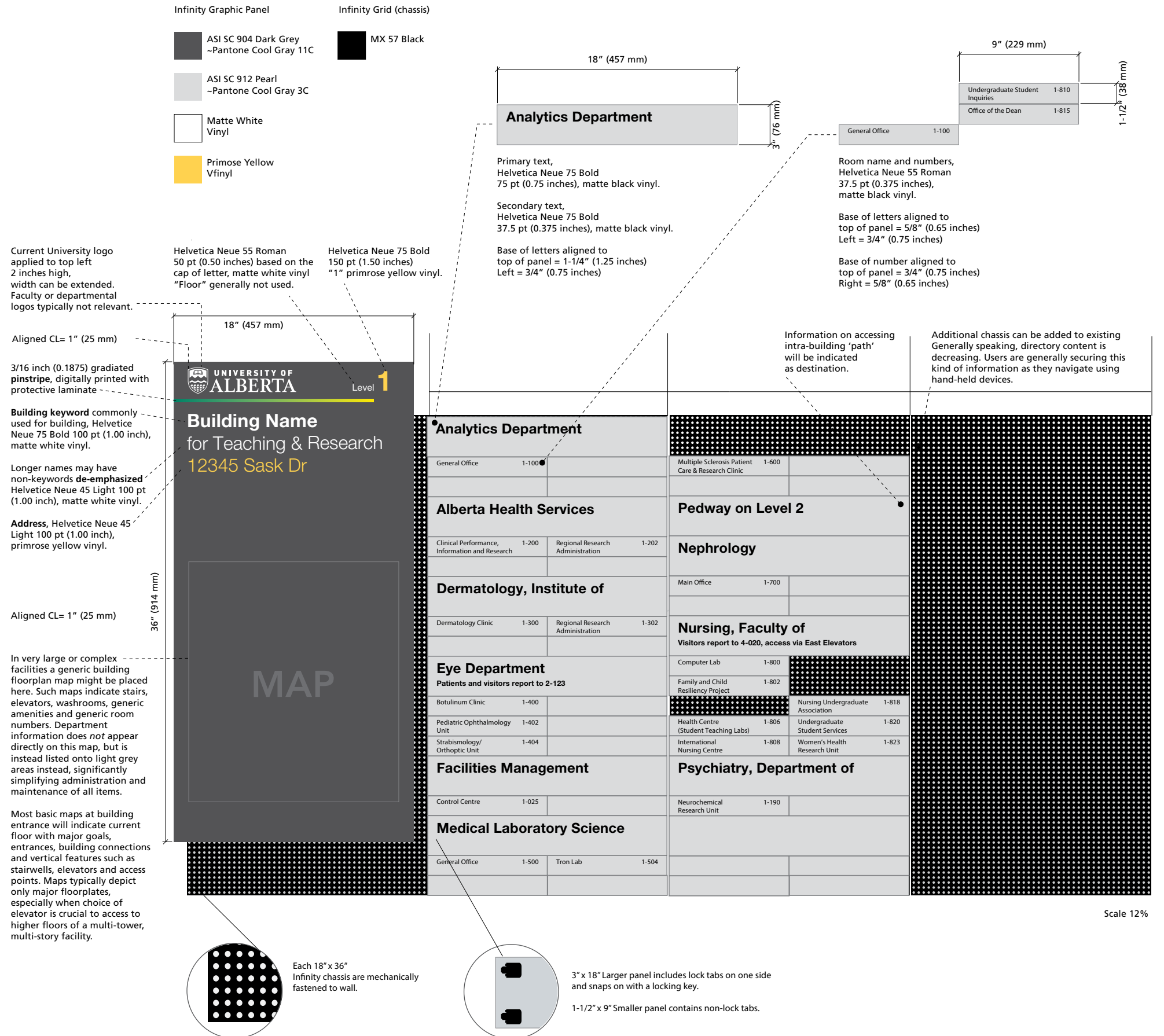

ST 8.0 DIRECTORIES & SUB-DIRECTORIES

This page shows some examples of directories and subdirectories. The process for choosing an appropriate building directory or subdirectory is to first determine appropriate and helpful content. The increased access to online information and prevalence of hand-held devices has meant decreasing need for directories and sub-directories. Information on the preceding page provides guidance on how to choose and organize appropriate content for directories and sub-directories.

Staff listings, once present in our older buildings (pre-2000) are not adopted on current directories for the following reasons:

- a) the sizes of our facilities are larger and staff lists would be cumbersome to organize and maintain;
- b) staff, faculty, and their duties are more subject to change than in the past;
- c) this sort of information is more conveniently shared in more readily-accessible formats (websites, e-mail signatures, etc).

Infinity Graphic Panel Infinity Grid (chassis)

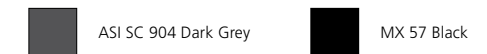

Approx. Pantone Color
(there is no actual pantone color match)

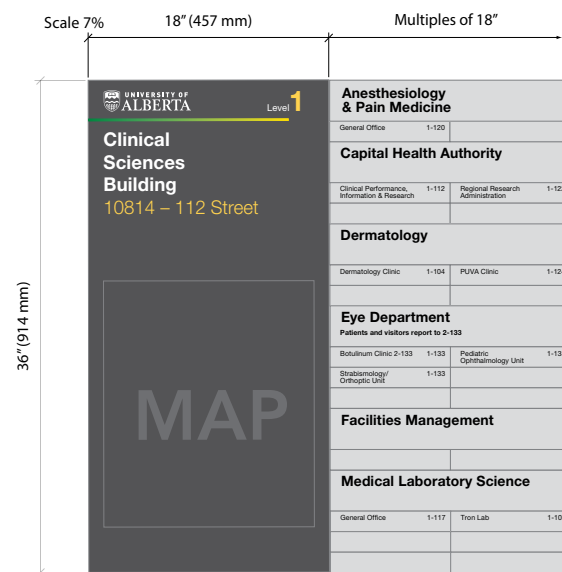
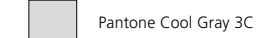

ST 8.1.1
Building entrance directory w/map organized by name

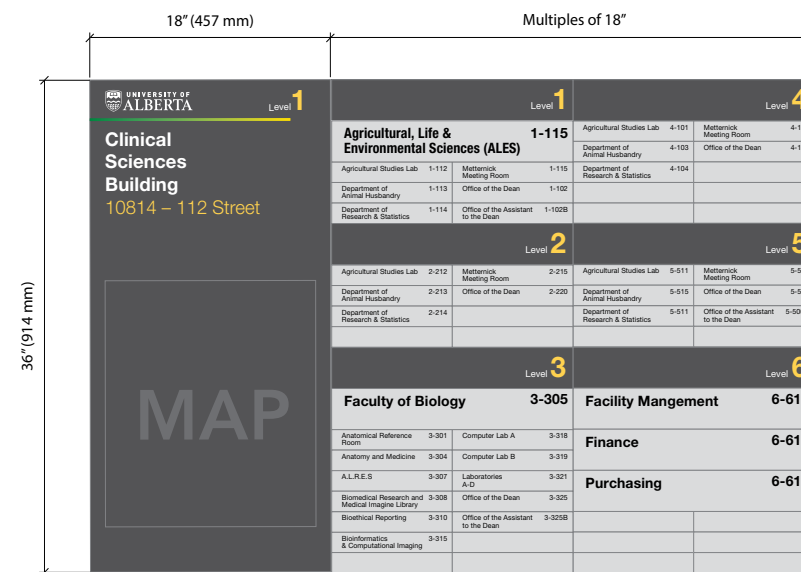

ST 8.1.2
Building entrance directory w/map organized by floor (this formatting methodology not encouraged)

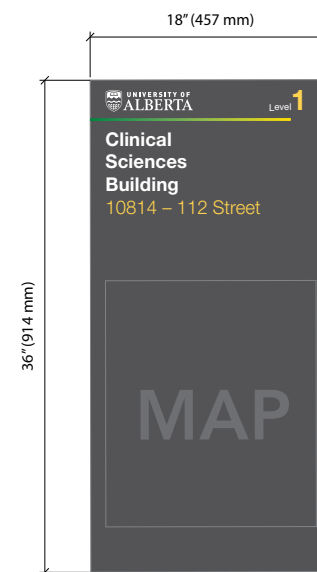

ST 8.2
Building map component

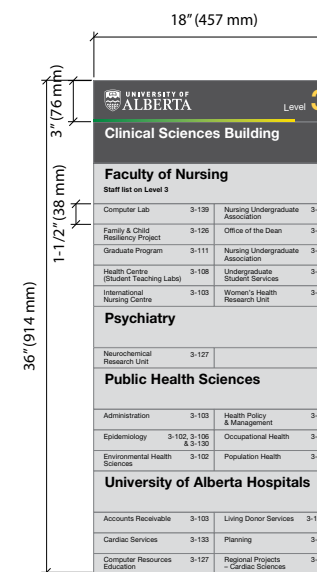

ST 8.3
Building directory component

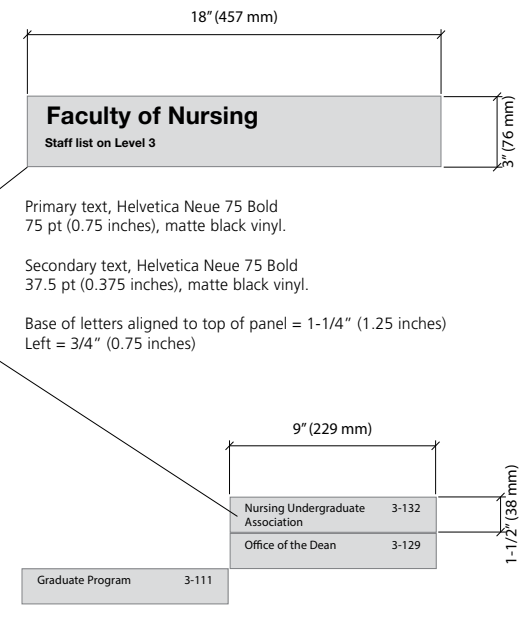

Room name and numbers, Helvetica Neue 55 Roman 37.5 pt (0.375 inches), matte black vinyl.

Base of letters aligned to top of panel = 5/8" (0.65 inches)
Left = 3/4" (0.75 inches)

Base of number aligned to top of panel = 3/4" (0.75 inches)
Right = 5/8" (0.65 inches)

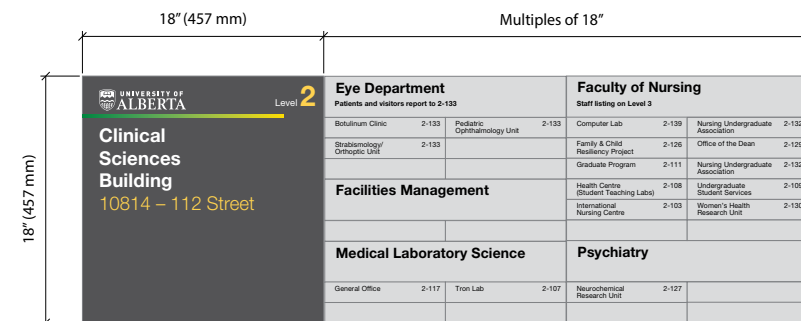

ST 8.4
Horizontal building directory component

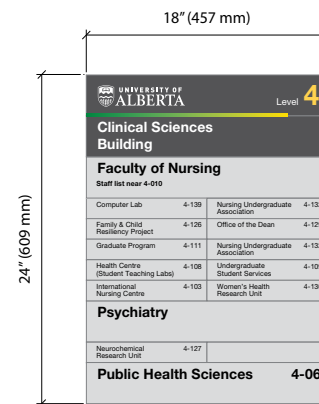

ST 8.5
Small format building subdirectory

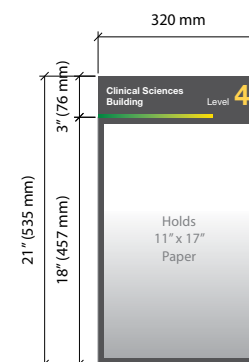

ST 5.8P/8.6P
Map Holder, tabloid size (portrait)

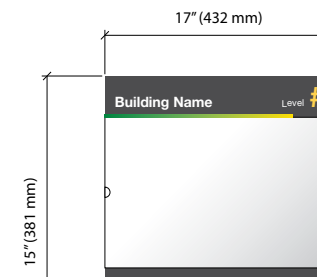

ST 5.8L/8.6L
Map Holder, tabloid size (landscape)

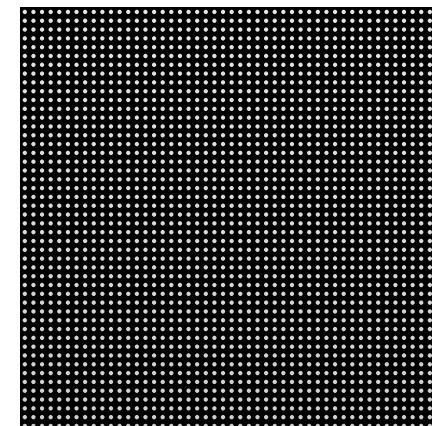

Infinity grid (chassis) comes in various sizes
An alternate chassis is used in some facilities.

confirm



ST 9.0 FACULTY/DEPARTMENTAL IDENTITIES

University logos are maintained and distributed by University Brand and Marketing within University Relations. Official logos are posted online at www.ualberta.ca/toolkit/downloads/logos. Also see page 3 information.

Faculty or departmental logos are not incorporated into directional pointer signs nor directories for reasons of formatting and clarity and because university facilities may have numerous faculties or departments,

However, officially endorsed University of Alberta logos may appear near wayfinding goals: where administrative staff can expect to receive and assist undergraduate or graduate students, alumni, or other official guests. Such logos tend to be found

- 1) at the entry point to administrative space, or
- 2) within a seated waiting or lobby area, or
- 3) as a backdrop to the administrative unit's reception counter.

The sizing and placement of University of Alberta logos is highly variable depending on site-specific architecture, furnishings, available space, lighting, and type of wall surface. The arrangement and composition of the logo may also accommodate a room number or room id sign/holder, or sometimes other appropriate visitor-specific messages.

Logos are generally never placed on the fronts of service counters because they would be typically obscured by people waiting in line.

The funding of these items are the financial responsibility of the faculty or department.



Illustrated example - measurements is based on 9' ceiling height.

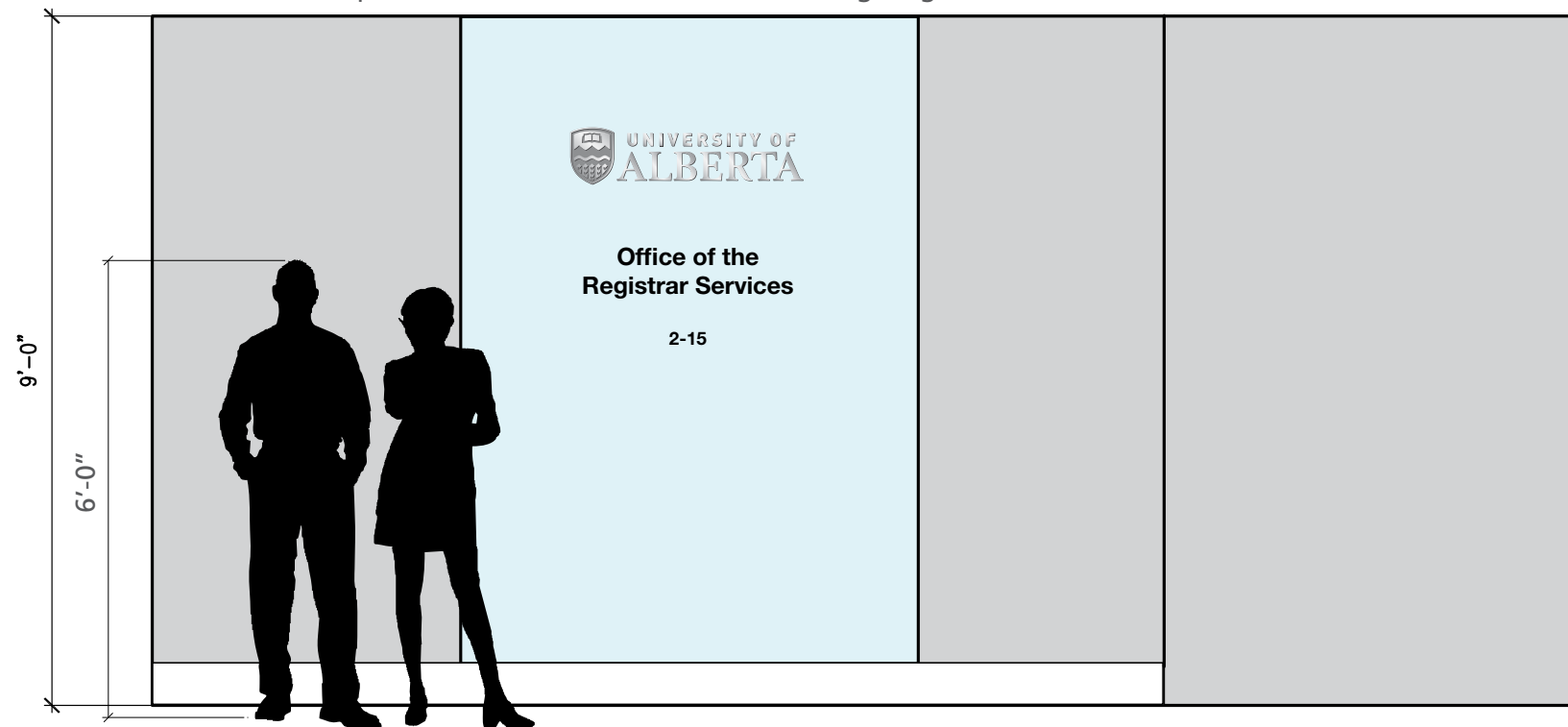

confirm



point



ST 10.0 INTERIOR BUILDING IDENTIFICATION & PEDWAYS

Interior building identifier signs are sometimes needed along interior corridors and pedways as one moves from building to building. Typically these signs appear as a pair, the sign with the arrow is placed on the side of the building being vacated. The sign without the arrow is used like a goal sign once the pedway has been crossed.

A goal signs, these do not attempt to communicate a facility's contents or occupants, but merely include three basic pieces of information:

- **Common-use building name or acronym.** This is typically the day-to-day wording spoken and used by staff and students, very often shorter than the full and complete facility name.
- **The full and complete version of the name,** helps to more fully explain and clarify the common-use name.
- **The floor level** is included so that the viewer is clear which level of the building is being entered and to minimize disorientation. This is very helpful when a pedway might act as a bridge from Level 3 in one building to a Level 2 in another.

Information about building occupants are not included and more appropriately placed and maintained in a building's directory or subdirectory.

Vinyl text and graphics may be arranged in similar ways on glass surfaces or brushed aluminum (as found on some automatic building door opener mechanisms).

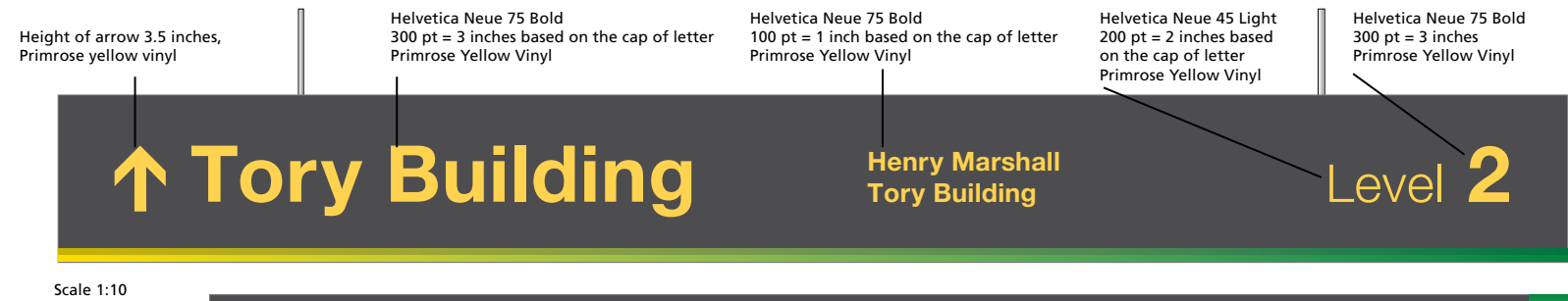

In cases where the pedway or door arrangement does not allow a sign because of door sensors and controls, similar format vinyl lettering can be applied to overhead door hardware in matte black vinyl

Text indicated in yellow is typically the very next building, and Level, without reference to internal entities.

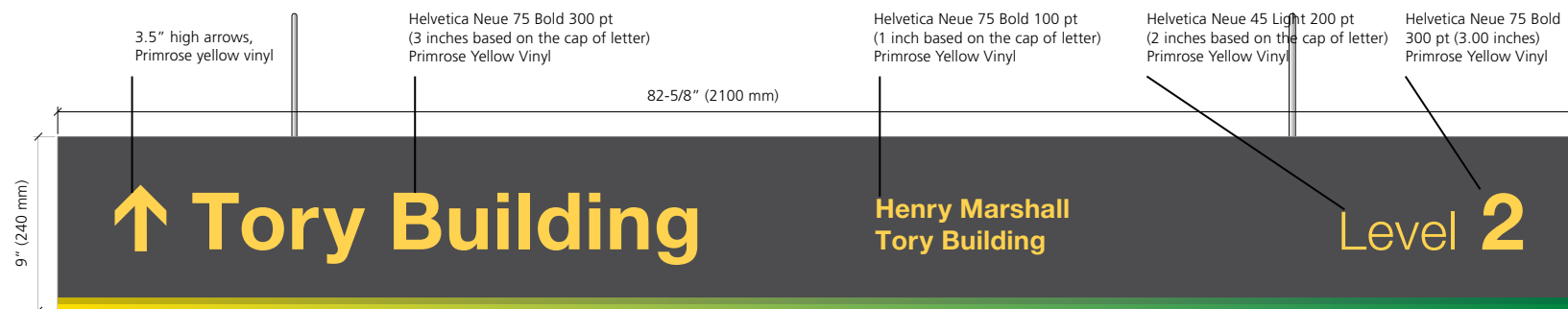
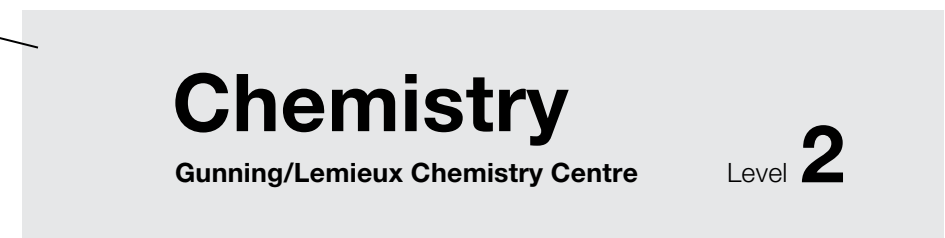
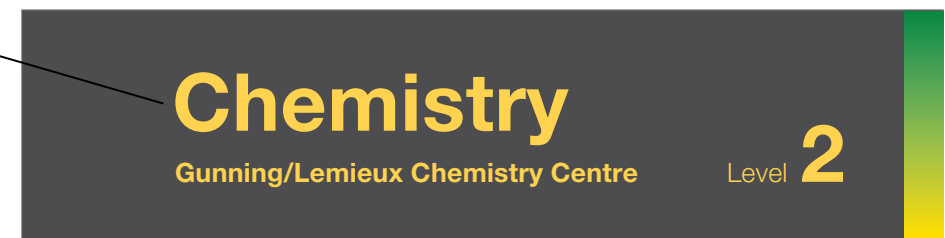

ST 10.3
Intra-Building Directional, Large Suspended



ST 10.4
Intra-Building Directional, Large Wall Mount

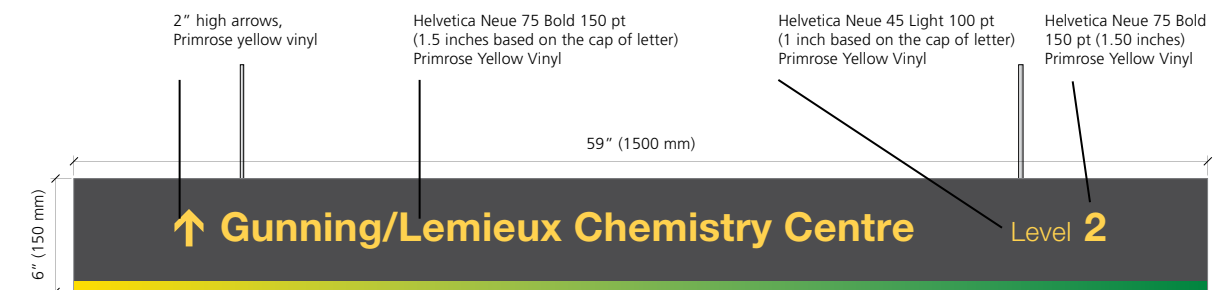

ST 10.1
Standard Intra-Building Directional, Suspended



ST 10.2
Standard Intra-Building Directional, Wall Mount

INSTALLATION GUIDELINES DIRECTORIES & DIRECTIONAL SIGNS

Signage is mechanically secured to walls with appropriate anchors and plugs in any public corridor. Tape with silicone may be used in internal office areas for employee ID signs.

Suspended and wall mounted signs need to avoid operational conflict with automatic door sensors, sprinkler heads, and emergency exit signage. The next few pages have additional details on fasteners, cables, and hardware.

Wall fastening hardware will vary depending on wall substrate (drywall, panel, woods, brick, tile, etc).

The installation heights vary with the type and role of the sign and vary with site conditions. Some examples are shown on the next few pages. In general, signs strive to be placed in a position that is within a 10 to 15 degree cone of vision from where one is naturally inclined to observe

the sign. In practice, signs are difficult to place within the lower portion in because of furniture, hand-rails, handles, water fountains, or trash receptacles. Any suspended overhead sign should usually be out of reach (or better still out of jumping reach). Most other items strive to have significant portions at about eye-level. Signs with braille strive to have their touch zone at roughly elbow to shoulder height.

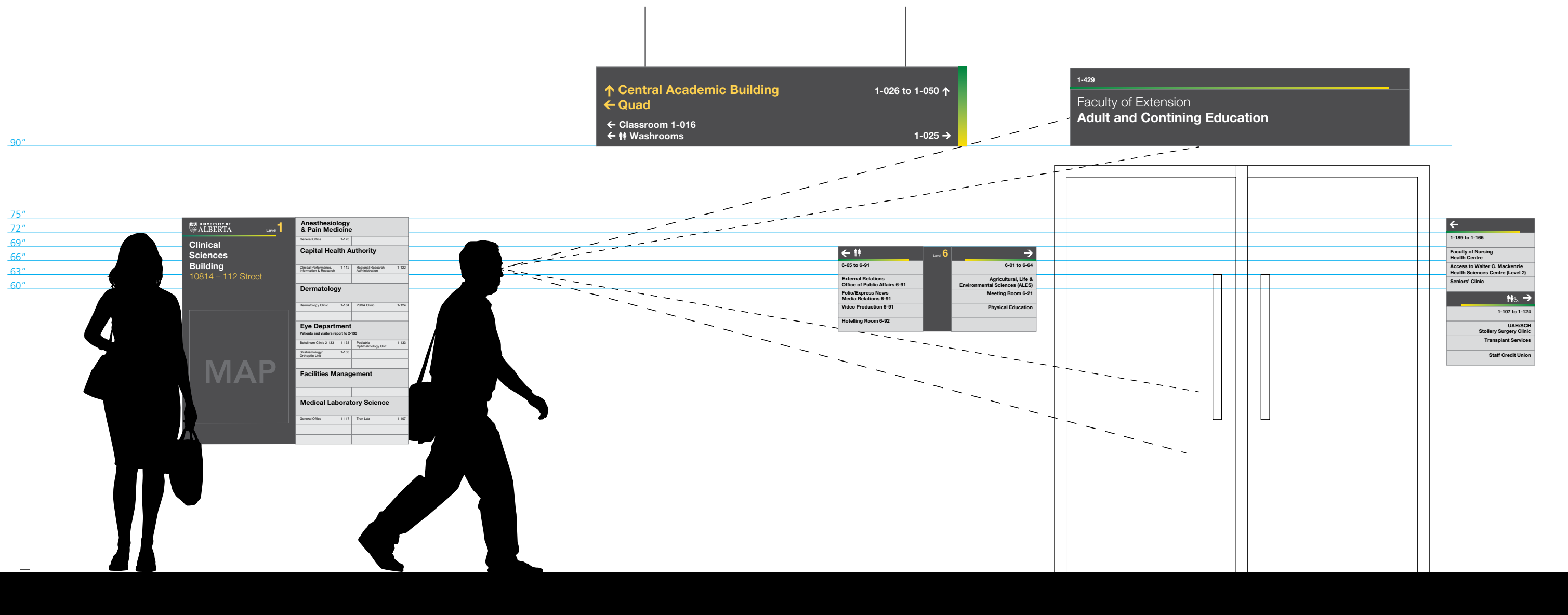

INSTALLATION GUIDELINES

ROOM & BASE ID

These positioning guidelines are intended as a starting point, and may need to be adjusted because of circumstances: things like surface seams, wall patterns, architectural details, positioning of light switches, trim style, might clash with these specification.

Installation of these items is intended to complement the environment they are in. Strive for common heights for any given sign type. Numerals on these signs strives to be 60 to 66 inches from floor in most instances.

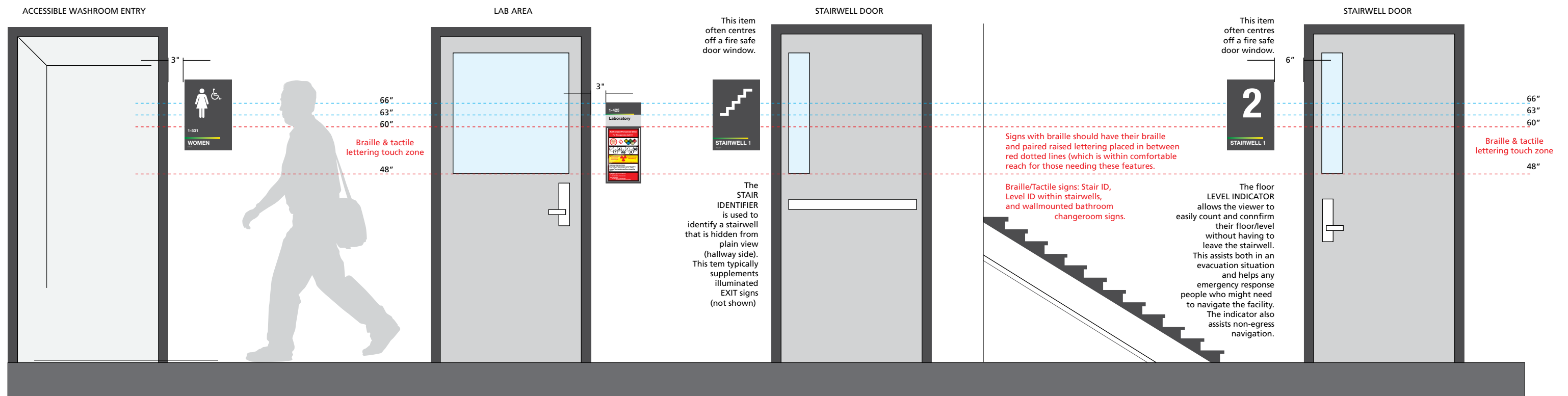
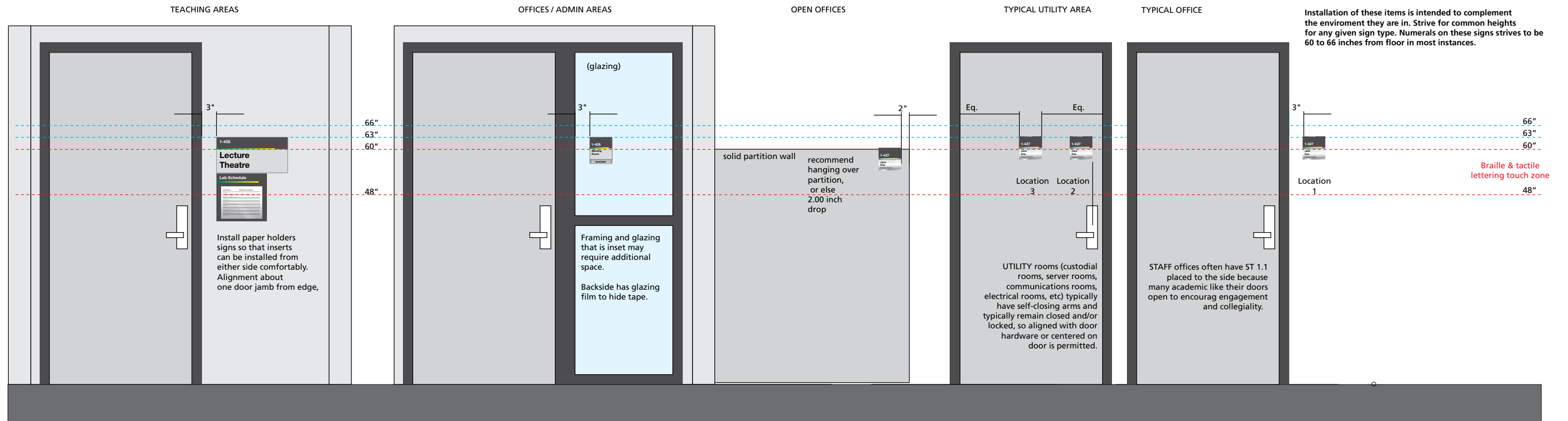

INSTALLATION GUIDELINES SUSPENDED SIGNAGE

GENERAL PLACEMENT

Even with the most careful planning, suspended signs may need to be installed several feet from planned locations because of mechanical infrastructure within ceiling or T-bar. Typically, slight relocations from plans are desirable to:

1. harmonize with nearby ceiling lighting,
2. avoid interference with automatic door sensors,
3. avoid line-of-sight obstructions of fire-exit signs, and/or
4. avoid blocking or obstructing automatic fire suppression systems (typically sprinkler heads)



Galvanized Steel Cable
 Model #: 2TAA2
 Size: 7x7, 1/16" x 250 ft
 Working Load Limit: 96 lbs

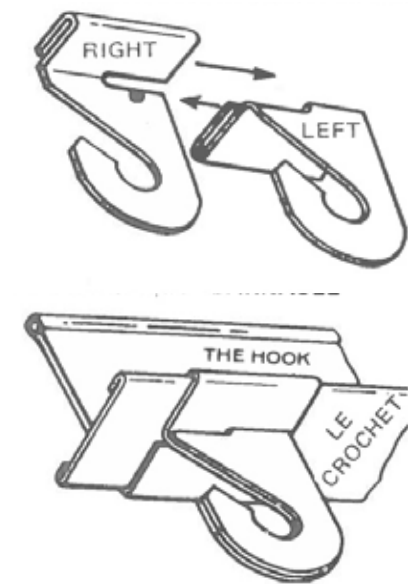

AIRCRAFT CABLE AND CLIPS

Most suspended signs are light enough to be suspended from ceiling tile using appropriate drop-ceiling clips and aircraft cable. In cases where additional support is necessary, see below.

DROP CEILING KIT, OPTION 1 (TOP RIGHT)

Signage suspended from drop ceilings can be mounted with either caddy clips (smaller signage) or via plywood braces located on the top of the hanging kit (for larger fabricated sign frames).

DROP CEILING KIT, OPTION 2 (BOTTOM RIGHT)

If additional reinforcement is required for signage coming through drop ceiling, it may be reinforced with a pipe and bracket system extending from the architectural ceiling to the top of the drop ceiling.

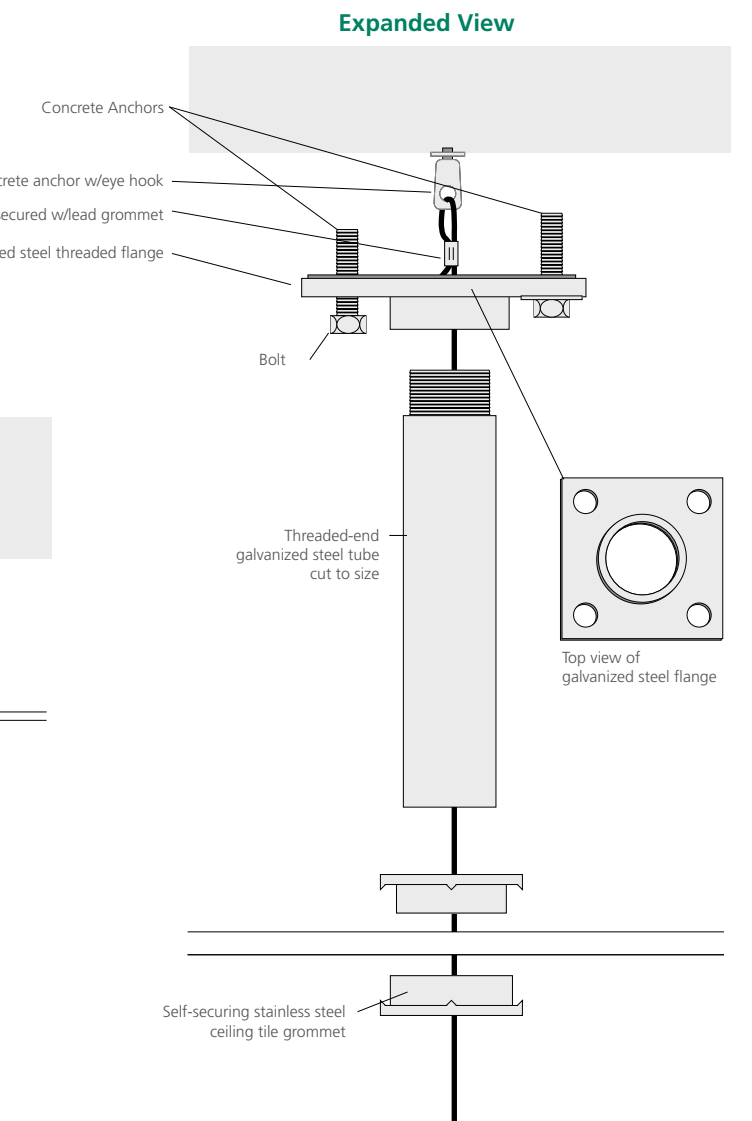
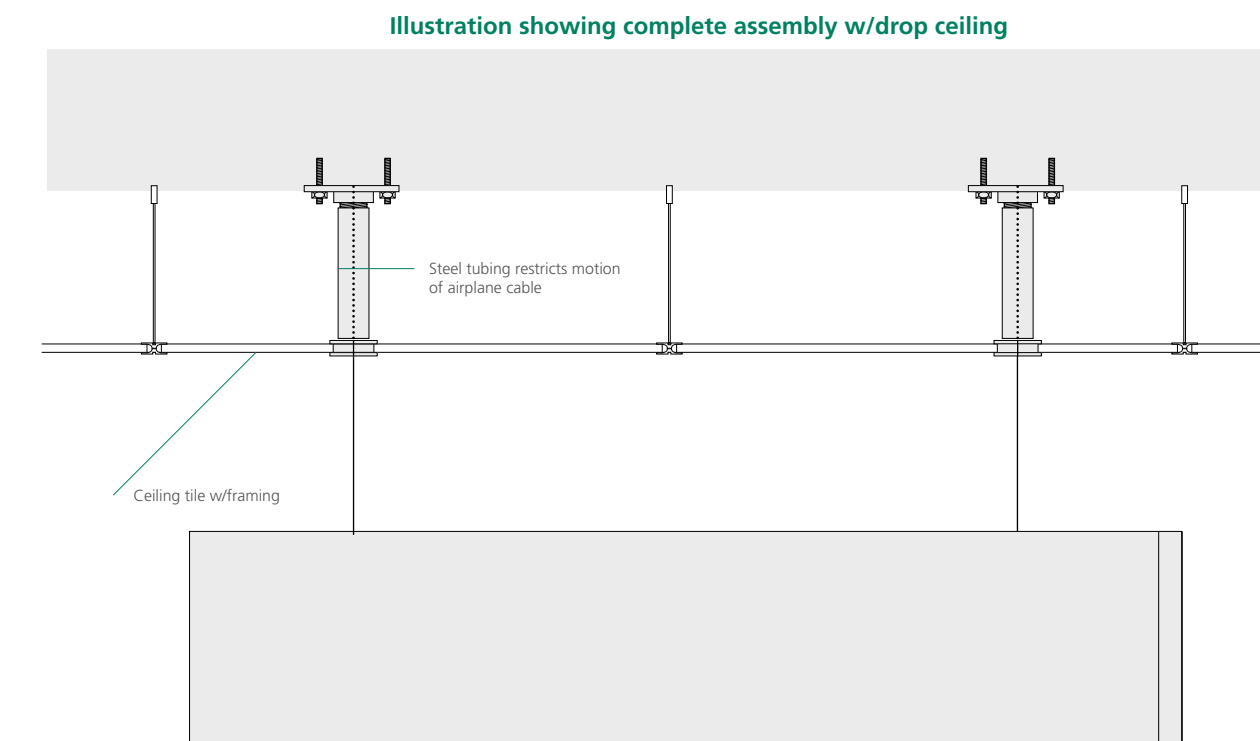
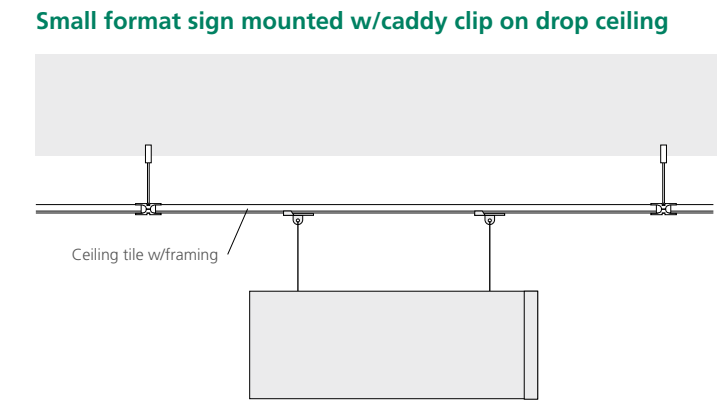
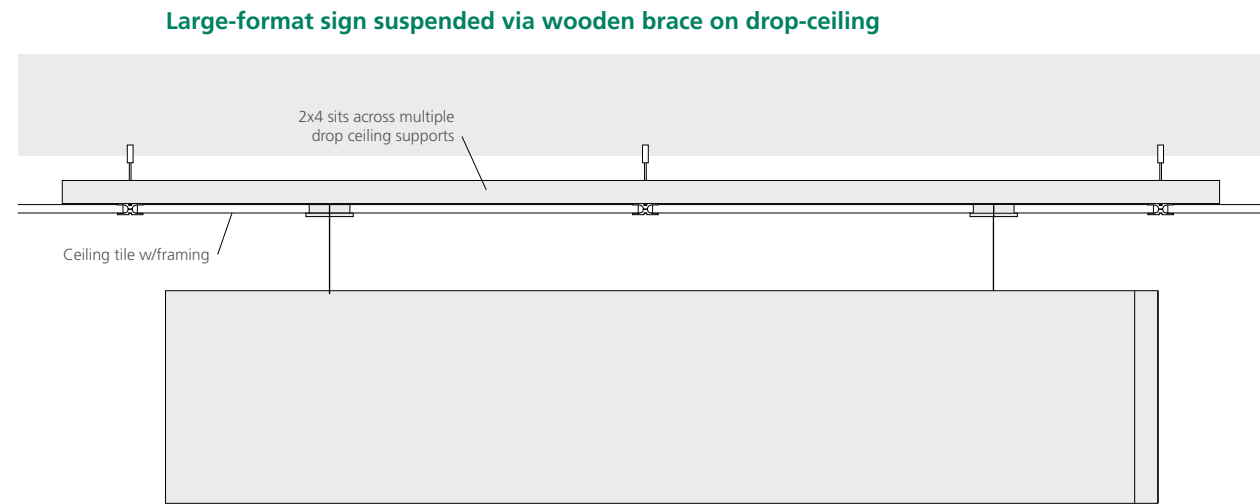

INSTALLATION GUIDELINES SUSPENDED SIGNAGE

CONCRETE-SUSPENDED SIGNS

In cases where there is no ceiling tile, suspended signs can use anchor plug similar to that depicted below. Such installations first require additional review to ensure that there are no hydronic systems present.

MOTION-FREE SUSPENDED SIGNS

Dual layers of steel rod may be used in areas with exceptionally high ceilings and/or with exceptionally long multiple-panel directional signs. Signs with this mounting condition will require additional review.

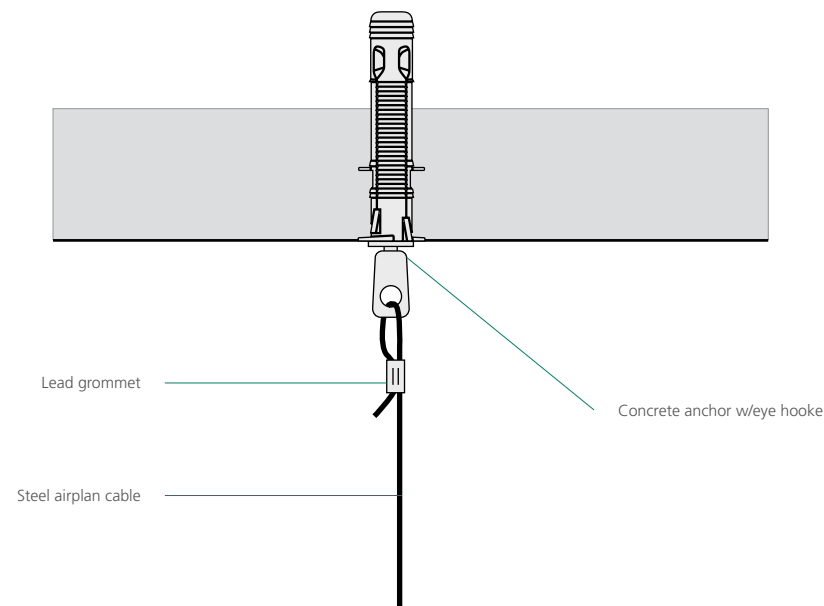
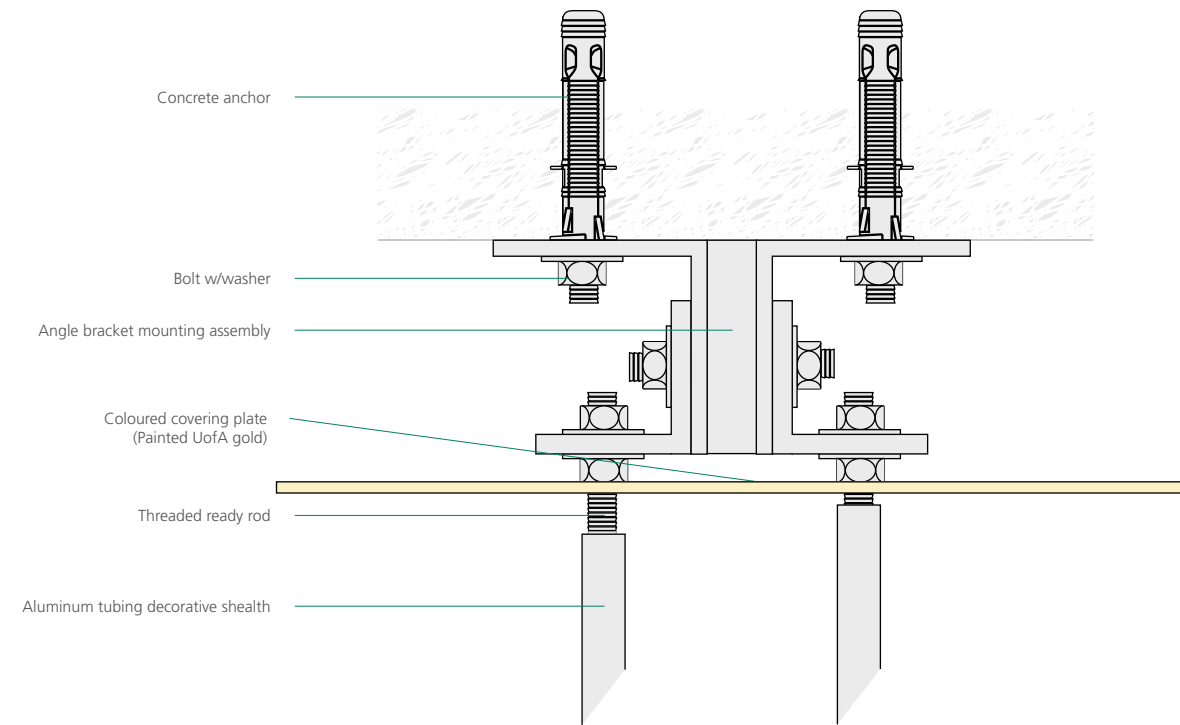

Standard mounting w/concrete anchor

Ceiling assembly for large format
(view perpendicular to sign face)

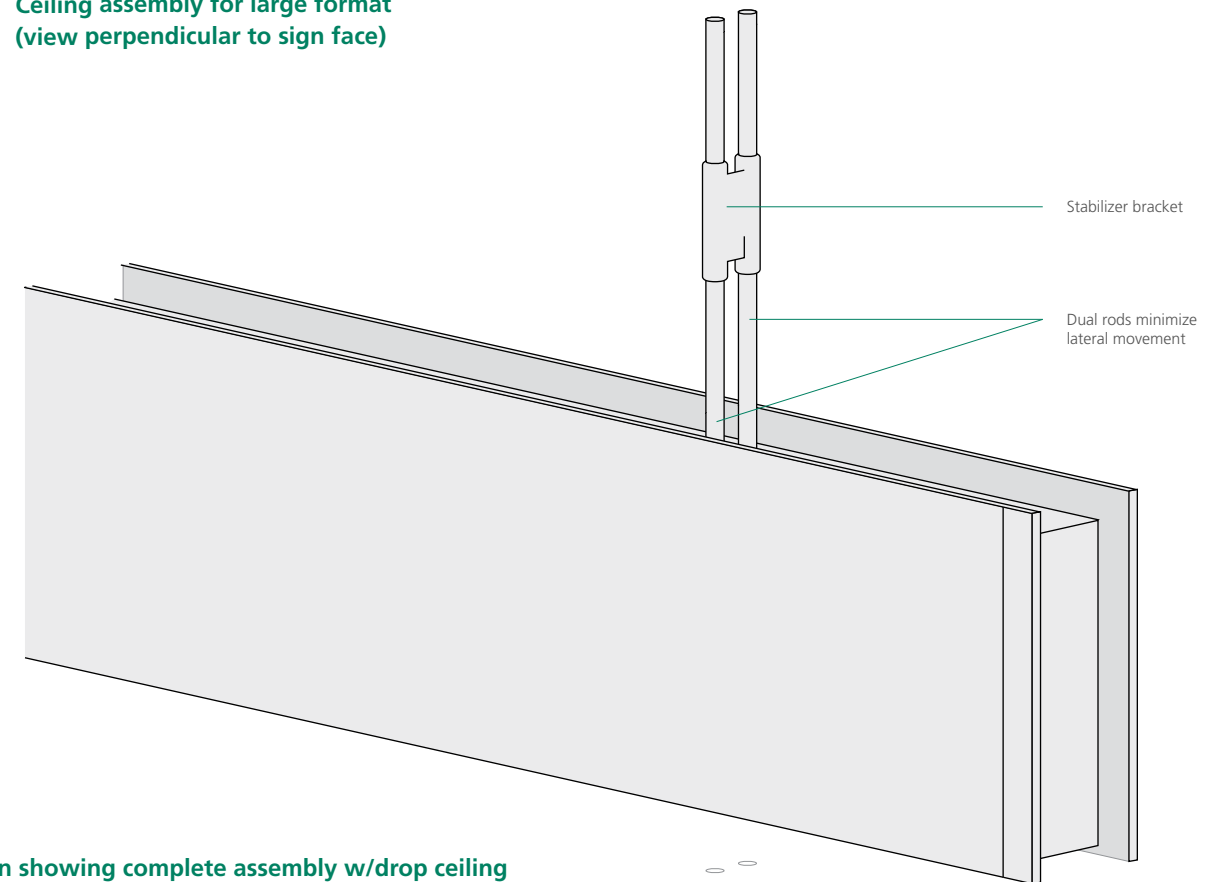

Illustration showing complete assembly w/drop ceiling

MAINTENANCE

CONTENT UPDATES

Many signs in the manual are paper-changeable and can be routinely updated directly by the signs owner using **sign templates** available at: <https://www.ualberta.ca/vice-president-facilities-operations/planning/signage-and-wayfinding.html> using "st1-personnel template" found in the "Workstation Identification" portion of that webpage.

Signs or directories requiring vinyl lettering or routed-out plastic lamacoid plates are initiated by completing a **Work Requisition**, found at:

<https://www.ualberta.ca/vice-president-facilities-operations/service-catalogue/buildings-grounds-and-environmental-services/work-requisition.html>

A work requisition is used to initiate the:

- Removal of an obsolete or demonstratively redundant sign (usually a legacy item abandoned by a previous tenant or administrative group)
- Replacement or repair for a sign damaged, vandalized, or otherwise in a state of disrepair.

Signage funding may be the responsibility of the administrative unit requesting the item or in some instances be covered by facility renewal or construction upgrades.



CLEANING

The signs in this manual are easy to maintain and require little or only very periodic cleaning and normally with the mildest of cleaning products. This is consistent with our institution's broader practices of choosing cleaning products that are:

- Eco-friendly,
- Scent-free (or unlikely to trigger those with scent or chemical sensitivities),
- Non-toxic,
- Economical and easily to source

Signs in this manual (excluding paper-changeable components) can be cleaned with a mixture of water, a mild or everyday dish-soap and, if necessary, a bit of vinegar.

When there is need to use a degreaser (typically to remove vinyl adhesive residue when changing vinyl lettering) a diluted citrus degreaser is recommended.

Do not use these items to clean interior signs:

- Methylated spirits, solvents or any acids
- Detergents containing abrasives
- Coarse cloth or cleaning brushes
- Powerful steam or high pressure cleaning equipment

Sign Type 1.1 Single Personnel ID

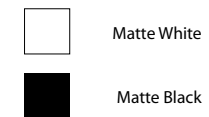
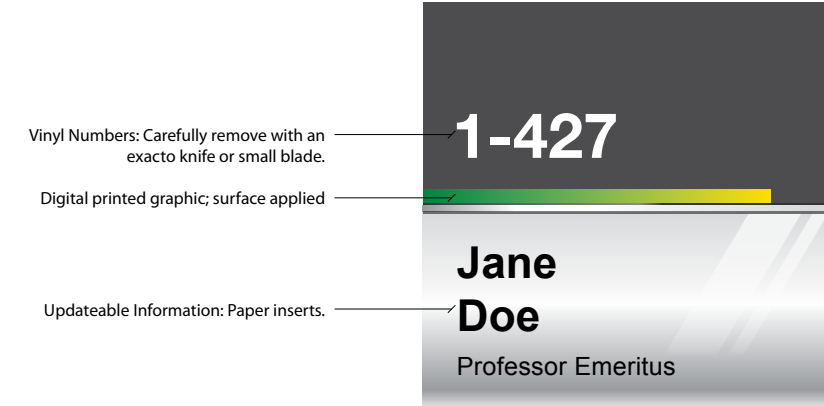

Personnel identification may or may not have endcaps to the sides of the paper-changeable area, depending on facility. Some of the endcaps also incorporate a commonly available Phillips screw.

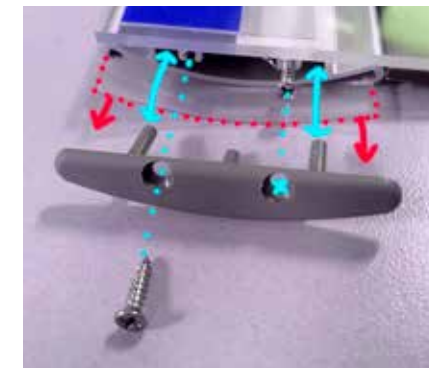

Sign Type 4.1 Standard Classroom ID

