

# **Mastercycler<sup>®</sup> / Mastercycler<sup>®</sup> gradient**

## **Operating Manual**



# Certificate

## **Authorized Thermal Cycler**

This instrument, Serial No. **5331** \_\_\_\_\_, is an Authorized Thermal Cycler.

This instrument, Serial No. **5333** \_\_\_\_\_, is an Authorized Thermal Cycler.

Its purchase price includes the up-front fee component of a license under the patents on the Polymerase Chain Reaction (PCR) process, which are owned by Hoffmann-La Roche Inc. and F. Hoffmann-La Roche Ltd., to practice the PCR process for internal research and development using this instrument. The running royalty component of that license may be purchased from Perkin-Elmer or obtained by purchasing Authorized Reagents. This instrument is also an Authorized Thermal Cycler for use with applications licenses available from Perkin-Elmer. Its use with Authorized Reagents also provides a limited PCR license in accordance with the label rights accompanying such reagents. Purchase of this product does not itself convey to the purchaser a complete license or right to perform the PCR process. Further information on purchasing licenses to practice the PCR process may be obtained by contacting the Director of Licensing at The Perkin-Elmer Corporation, 850 Lincoln Centre Drive, Foster City, California 94404.

Transfer of the thermal cycler without serial number and/or this certificate terminates the authorization and the thermal cycler shall cease to be an Authorized Thermal Cycler.

Perkin-Elmer does not guarantee the performance of this instrument.

No part of this publication may be reproduced without the prior permission of the copyright owner.  
Copyright© 1997 by Eppendorf – Netheler – Hinz GmbH, Hamburg

Mastercycler® is a registered trademark  
US Reg. No. 2,273,536  
Canadian Reg. No. TMA510572

# Contents

<b>1</b>	<b>Introduction</b> .....	<b>3</b>
<b>2</b>	<b>Safety precautions</b> .....	<b>4</b>
<b>3</b>	<b>Installation</b> .....	<b>5</b>
3.1	Delivery package .....	5
3.2	Setting up the device .....	5
3.3	Starting up the device .....	5
<b>4</b>	<b>Technical description</b> .....	<b>6</b>
4.1	Device construction .....	6
4.2	Keys .....	7
4.3	Display .....	8
<b>5</b>	<b>Description of menus</b> .....	<b>9</b>
5.1	Main menu .....	9
5.2	Start .....	10
5.3	FILES .....	10
5.3.1	Edit .....	10
5.3.2	Load .....	11
5.3.3	Standard .....	11
5.3.4	New .....	11
5.3.5	Delete .....	11
5.4	OPTIONS .....	12
5.4.1	Editor .....	12
5.4.2	Printer .....	13
5.4.3	Gradient .....	13
5.4.4	GENERAL .....	15
5.5	Lid .....	17
5.6	Incubate .....	18
<b>6</b>	<b>Operation</b> .....	<b>19</b>
6.1	Preparation .....	19
6.1.1	Loading the samples .....	19
6.1.2	Sample volume .....	20
6.1.3	Heated lid .....	20
6.1.4	Temperature-control of the block .....	20
6.2	Switching on the device .....	21
6.3	Starting a program .....	21
6.4	Displaying the running time of a program .....	23
6.5	Interrupting a program .....	23
6.6	Continuing an interrupted program .....	24
6.7	Aborting a program .....	24
6.8	Switching off the device .....	24
<b>7</b>	<b>Programming</b> .....	<b>25</b>
7.1	Command description .....	25
7.1.1	CNTRL .....	25
7.1.2	Lid .....	26
7.1.3	T .....	26
7.1.4	HOLD .....	28
7.1.5	PAUSE .....	28
7.1.6	GOTO .....	28
7.1.7	SOUND .....	28
7.1.8	LINK .....	28
7.1.9	END .....	29

7.2	Creating a new program . . . . .	29
7.2.1	Programming . . . . .	30
7.2.2	Saving a program . . . . .	32
7.3	Modifying a program . . . . .	33
7.4	Creating programs using an example program. . . . .	35
7.5	Deleting a program . . . . .	35
7.6	Examples of programming . . . . .	36
7.6.1	Gradient PCR (for Mastercycler® gradient only) . . . . .	36
7.6.2	Hot Start PCR. . . . .	36
7.6.3	Touch Down PCR . . . . .	37
7.6.4	Long PCR . . . . .	38
7.6.5	PCR "Fingerprinting" (RAPD-PCR) . . . . .	39
7.6.6	Sample cooling and subsequent PCR . . . . .	40
<b>8</b>	<b>Short instructions</b> . . . . .	<b>41</b>
<b>9</b>	<b>Personal card</b> . . . . .	<b>43</b>
9.1	Safety precautions . . . . .	43
9.2	Operation . . . . .	43
9.3	Processing programs . . . . .	44
<b>10</b>	<b>Interface description</b> . . . . .	<b>45</b>
10.1	Printer / PC connection . . . . .	45
10.2	Program transfer . . . . .	48
<b>11</b>	<b>Maintenance</b> . . . . .	<b>49</b>
<b>12</b>	<b>Troubleshooting</b> . . . . .	<b>50</b>
12.1	Error messages . . . . .	50
12.2	Test program . . . . .	55
<b>13</b>	<b>Technical data</b> . . . . .	<b>56</b>
<b>14</b>	<b>Ordering information</b> . . . . .	<b>57</b>
<b>15</b>	<b>Index</b> . . . . .	<b>59</b>
	<b>EC Conformity Declaration</b>	

# 1 Introduction

The Eppendorf Mastercycler® and Mastercycler® gradient are PCR devices for all molecular biological and biochemical laboratories in the field of basic research or routine diagnostics.

Temperature control is carried out with Peltier elements, which enable extremely rapid changes in temperature of up to 3 °C per second. This allows the temperature of the samples to be controlled extremely rapidly between 4 °C and 99 °C.

A special "tube control" mode has been developed for temperature-controlling samples in various different tubes with various different filling volumes.

The thermoblock has been constructed as a universal block which can accommodate microtiter plates in the 8 x 12 format, 96 Eppendorf PCR test tubes of 0.2 ml, 77 thin-walled Eppendorf PCR test tubes of 0.5 ml or other suitable tubes – without the block having to be exchanged.

With the aid of the *in situ* Adapter, *in situ* reactions may be carried out on up to four glass slides.

To prevent the formation of condensation, the devices have a heated lid which has been perfectly tailored to suit all tubes.

The devices are easy to operate, with user guidance available in the integrated, eight-line display. Experiments and tests can be documented with the aid of a printer which may be connected up to the devices.

One particular advantage of the Mastercycler® gradient is the Gradient function, which greatly facilitates the optimization of PCR experiments. The gradient enables the temperature across the entire block to be varied within a range of up to 20 °C; it can be programmed with every temperature step.

.The Mastercyclers are authorized cyclers licensed by the Perkin-Elmer Corporation.



## 3 Installation

### 3.1 Delivery package

The delivery package contains the following items:

- 1 Mastercycler<sup>®</sup> or Mastercycler<sup>®</sup> gradient
- 1 Main power cable
- 1 Operating manual (German / English)
- 1 Personal card
- 1 bag of 0.2 ml PCR test tubes (100 pieces)
- 1 bag of 0.5 ml PCR test tubes (100 pieces)

### 3.2 Setting up the device

When setting up the device, please ensure that enough space is available to allow the ventilation slit to remain uncovered and to allow air to flow under the device for cooling purposes. Please ensure that no objects are under the device (e.g. lab bench paper).

No special equipment is required for transporting the device. It can be lifted up and carried by being held on both sides.

Space requirements: Width: 26 cm  
Depth: 41 cm  
Height: 27 cm

Mains connection: 1 shockproof socket for the Mastercycler<sup>®</sup> / Mastercycler<sup>®</sup> gradient.  
If a printer is to be connected up, a second mains connection must be used.

The delivery packaging should be stored in a safe place to enable the device to be shipped in the event that repairs are necessary.

### 3.3 Starting up the device

Remove the adhesive strip on the heated lid and take out the bubble-wrap from below the heated lid.

The Mastercycler<sup>®</sup> / Mastercycler<sup>®</sup> gradient is connected to the mains supply using the mains cable. Before starting up the device, please compare the power supply with the voltage requirements listed on the identification plate (see Sec. 4.1, Fig. 3.5).

The procedure for connecting and starting up a printer is described in Sec. 10.1.



## 4 Technical description

### 4.1 Device construction

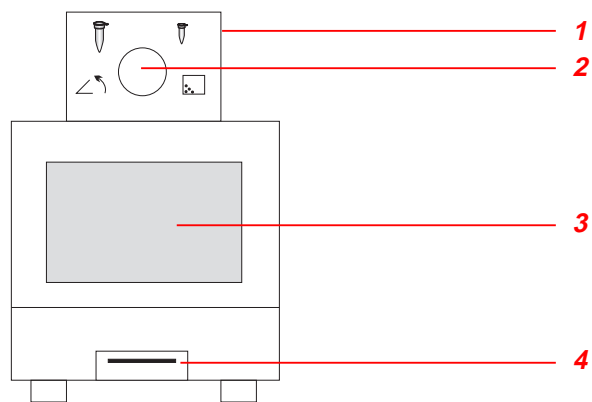

**Fig. 1: Front view**

- 1 Heated lid
- 2 Locking button
- 3 Display and control panel
- 4 Personal card reader

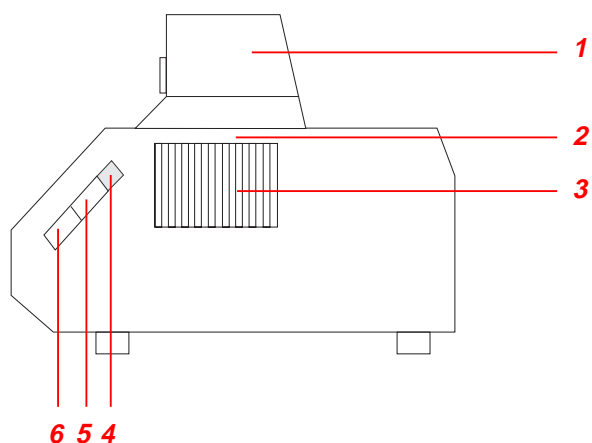

**Fig. 2: Side view**

- 1 Heated lid
- 2 Thermoblock (not visible in this picture)
- 3 Ventilation slit
- 4 Brightness regulator
- 5 PC connection socket
- 6 Printer connection socket

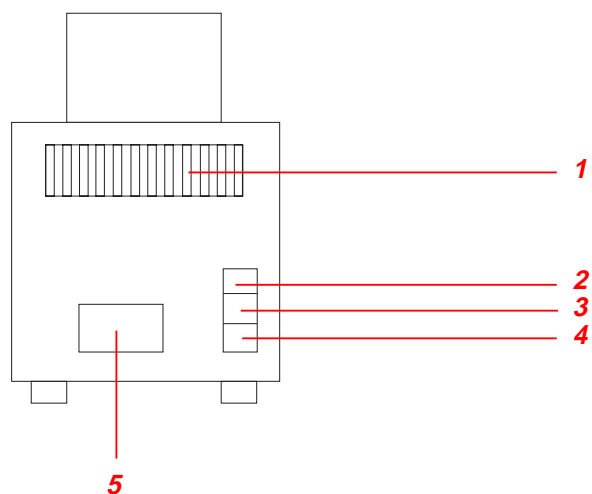

**Fig. 3: Rear view**

- 1 Ventilation slit
- 2 Main power switch
- 3 Fuses
- 4 Main power socket
- 5 Identification plate

## 4 Technical description

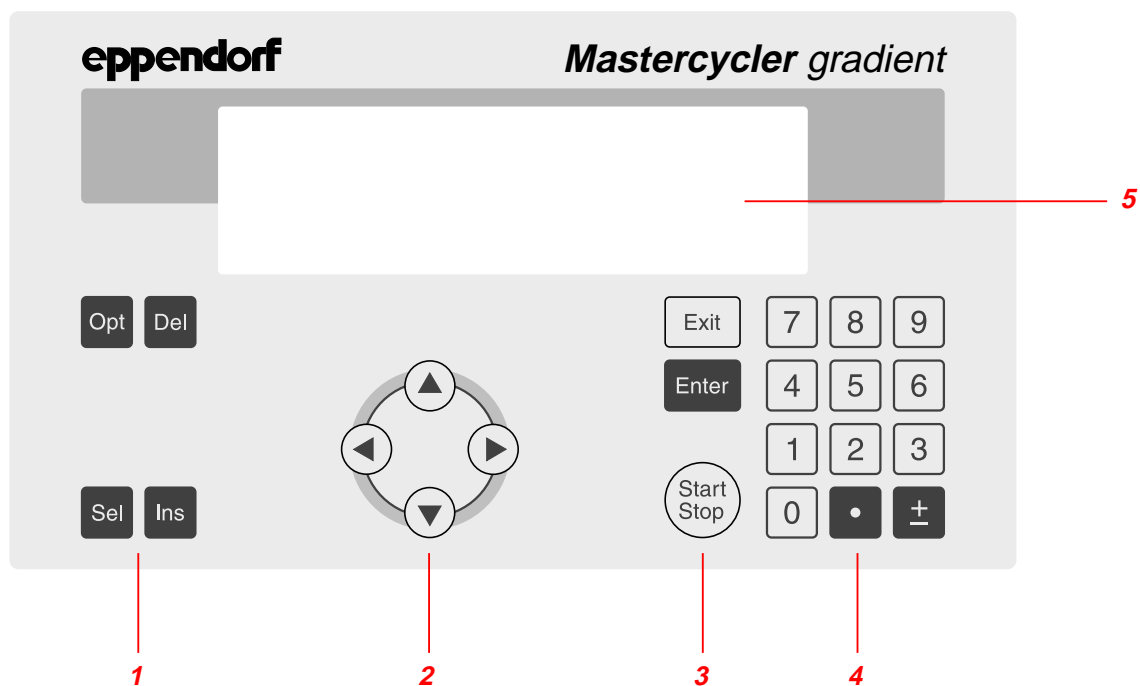

**Fig. 4: Display and control panel**

- 1 Programming keys
- 2 Cursor keys
- 3 Control keys
- 4 Digit entry block, decimal point and reverse sign key
- 5 Display

### 4.2 Keys

#### Programming keys



- Opt**
- When this key is pressed, the approximate remaining run time of a program and the time of the expected end of the program appears in the display for approximately five seconds.
  - To select programming options for the "Temperature" command (ramp, gradient, increment).
- Del**
- To delete program lines, digits or letters or to reset parameters. Holding down the key deletes not only individual letters but also a complete name.
- Sel**
- To select a program command or to select from a list.
  - A menu item can be selected using the **Sel** key instead of the  $\blacktriangle$  /  $\blacktriangledown$  keys.
  - The **Sel** key can also be used to select from a list and to enter the letters of program names. The direction of selection of the letters can be changed by pressing the  $\pm$  key.
- Ins**
- To insert program lines during the creation of a program.

## 4 Technical description

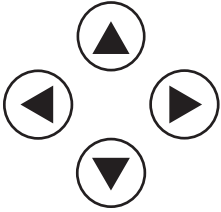
### Cursor keys



The cursor appears in the display as a dark field.

- If a menu should be selected, the cursor must be moved to that menu and the selection should then be confirmed by pressing .
- The cursor is also used to move into, or to change between, input fields. Entries do not have to be confirmed by pressing ; they are stored immediately.

### Control keys



- To exit a menu or to return to the next-highest menu level.
- After a program has been started, the display of the program can be exited, e.g. in order to work in the programming level.



- To call up a menu which has been selected using the cursor.
- To confirm an entry.



- To quick-start a program from the processing level ("FILES/Edit" menu). If another program needs to be started, the "Start" menu must be used.
- To cancel or to interrupt a program.

### 4.3 Display

Press the main power switch on the rear of the device (Sec. 4.1, Fig. 3.2). The device name and the software version installed appear briefly in the display.

The main menu then appears in the display:

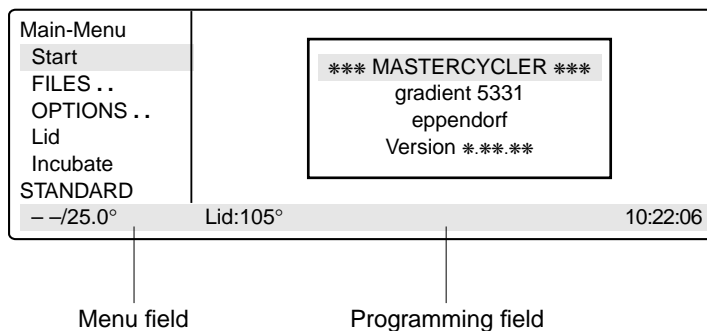

The eight-line display is divided into two areas. The menu field on the left-hand side contains a list of the selectable programs. The programming field is used for programming and for setting the device parameters.

# 5 Description of menus

## 5.1 Main menu

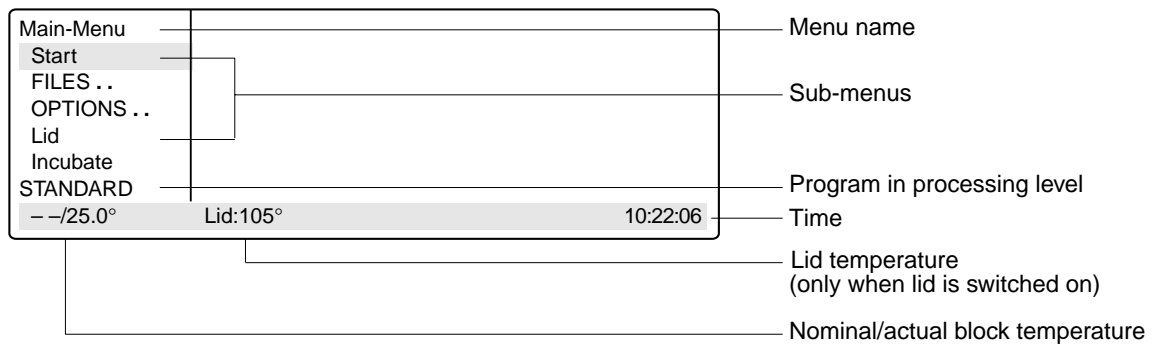

A menu or a sub-menu can be called up in three different ways:

1. Select using the  $\uparrow$  /  $\downarrow$  keys and confirm by pressing .
2. Select using the  key and confirm by pressing .
3. Select the menu using the internal position number (shown in brackets in the text) and confirm by pressing .

The program in the processing level can be started immediately by pressing the  key. Menus are exited by pressing the  key. To access the main menu, it may be necessary to press the  key several times. Menus written in capital letters have additional sub-items. For ease of reference, the menu name appears on the left-hand side of the display or as a headline above the menu or as a sub-item.

Overview of the entire menu structure:

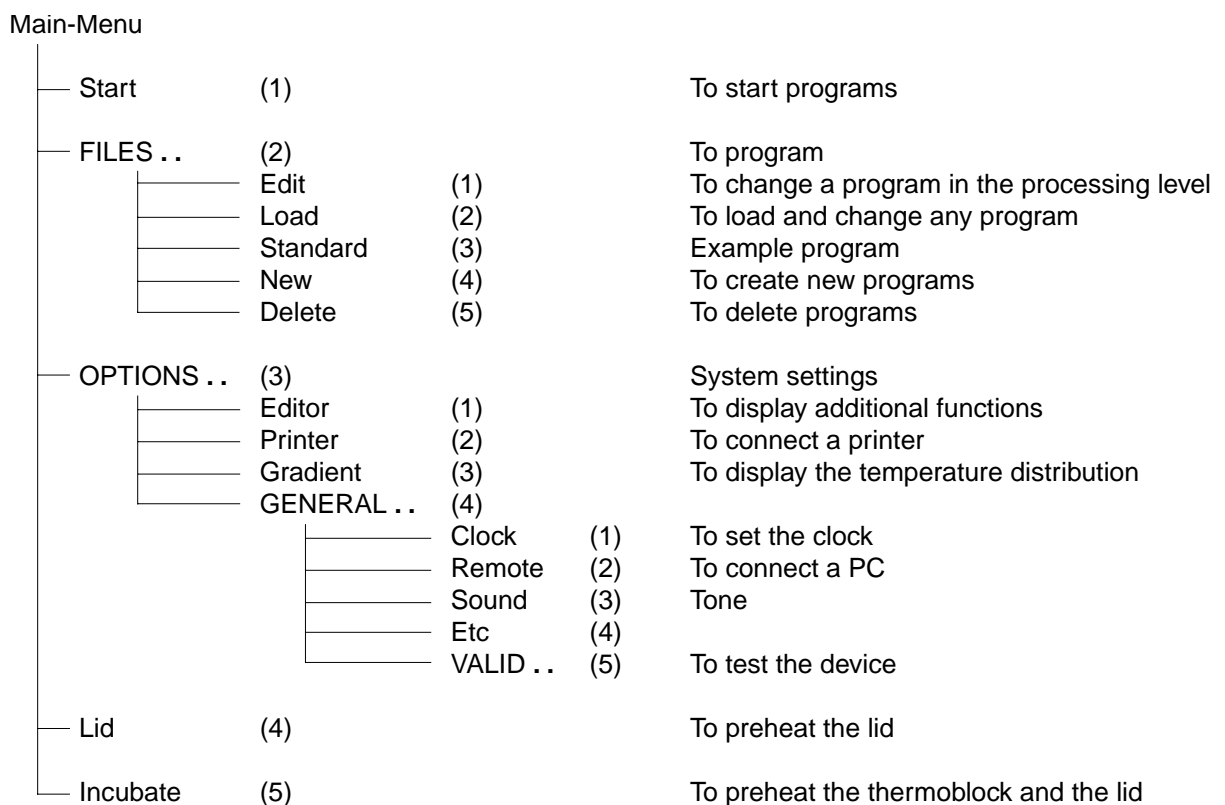



# 5 Description of menus

## 5.2 Start

Only programs can be started from the "Start" menu.

The program displayed in the processing level can be started directly by pressing the  key (1).

If a program which has been stored has to be started, it is selected with the cursor keys from the displayed list after  has been pressed (2) and confirmed by pressing .

The "Start" menu has no sub-programs.

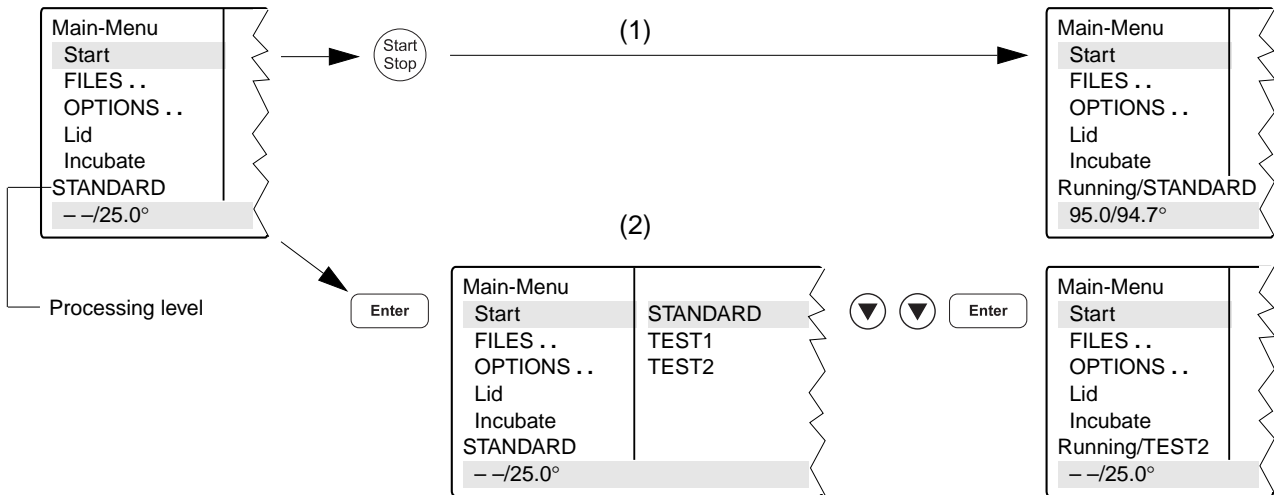

## 5.3 FILES

The "FILES" menu is used to change, load, create or delete programs.

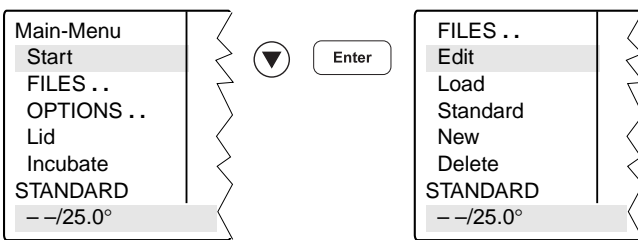

### 5.3.1 Edit

The "Edit" menu is used to change existing programs. The program which is to be changed may already be in the "processing level" or it is loaded into the processing level via the "Load" menu. This is applicable for programs from the internal device memory or from a personal card.

The program which has been changed can be checked by pressing the  key after the program has been saved under a new name. The processing level is not deleted when this program is saved. The program data remains stored even when the device is switched off and is overwritten only when the "New" or "Standard" sub-menu is called up.

**Note:** If the program which has been changed (without being saved under a new name) is started, there are then two different programs with the same name (one in the internal memory and one in the processing level).

## 5 Description of menus

### 5.3.2 Load

"Load" is used to call up a list of existing programs. These programs may be taken from the internal memory or from a personal card. The selected program is loaded into the "Edit" processing level. If the "Edit" processing level contains a program which has not been saved, a safety check appears in the display, which then enables the program to be saved.

If the user does not want to save the program, it is overwritten when the new program is loaded. As the "Edit" processing level is called up automatically, the program can be changed immediately and can then be tested for test purposes.

The procedure for loading programs from a personal card is described in Sec. 9.3.

### 5.3.3 Standard

An example program called "Standard" is available for creating new programs. It is not necessary to rewrite a program completely; the example program can be supplemented or changed and then saved under a new name. All programs which are in the internal memory can be used as an example program.

Following a safety check, the example program is loaded into the processing level. The process is described in more detail in Sec. 7.4.

Although the "Standard" example program cannot be deleted, it can be changed to suit individual requirements. After the changes have been made, the example program is saved under the name "Standard". To restore the original example program, the "Standard" program must be deleted in the "Delete" sub-menu. When "Standard" is called up again, it is the original example program which is then loaded into the processing level.

### 5.3.4 New

"New" can be used to call up the processing level automatically. To create a new program, an existing program is deleted.

The essential input CNTRL BLOCK, Lid =0°, NOWAIT AUTO, end is simulated automatically and the program is given the provisional title UNNAMED.

### 5.3.5 Delete

Programs can be deleted from the internal memory or from a personal card. After "Delete" has been selected, a list of program names appears in the display. A program can be selected from this list using the cursor key and can be deleted by pressing . The program in the processing level cannot be deleted.

The procedure for deleting programs from a personal card is described in Sec. 9.3.

## 5 Description of menus

### 5.4 OPTIONS

The "OPTIONS" menu can be used to define general system settings for the program editor, printer, time/date, etc.

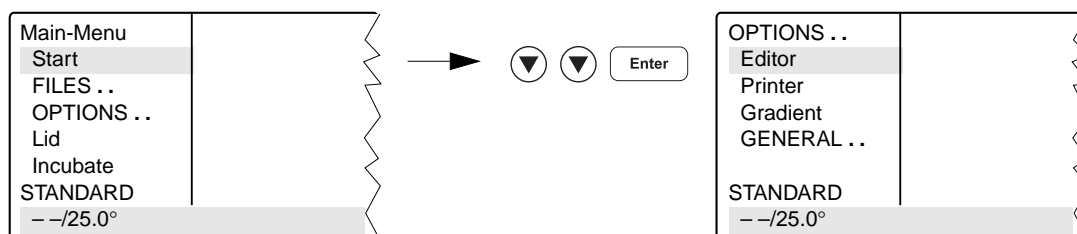

Selection of YES/NO, ON/OFF and other settings can be carried out using the **Sel** key.

The menu is exited by pressing the **Exit** key.

#### 5.4.1 Editor

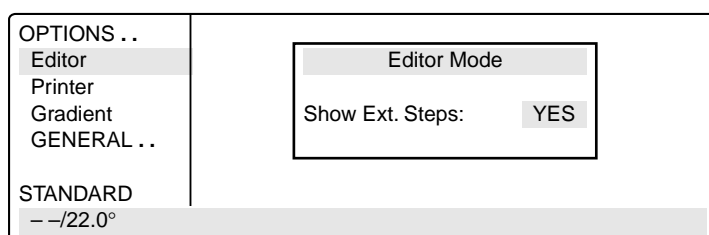

**Show Ext. Steps** To display temperature options.

**YES** All options (temperature increment, time increment, ramp, ramp increment, gradient) for each step appear in the display.

**NO** Only the nominal temperature and the cycle time appear in the display. If the options have been defined, the command is marked with an "\*" for information purposes when the program is called up. Nonetheless, the options can be called up by pressing the **Opt** key and can then be entered or displayed.

## 5 Description of menus

### 5.4.2 Printer

OPTIONS ..	
Editor	
Printer	
Gradient	
GENERAL ..	
STANDARD	
--/22.0°	

Printer Mode

Printout Editor:  NO

Print Protocol:  OFF

Entries are necessary only when a printer is connected.

#### ***Printout Editor***

YES: The program in the "Edit" processing level is printed out.  
If "YES" has been selected, but no printer is accessible, the error message "Printer: No Response" appears in the display.

NO: Appears automatically when the program printout has finished.

#### ***Print Protocol***

ON: When the program starts, the commands are printed out; during the run, every completed command is printed out together with the time.

OFF: No printout is made.



## 5 Description of menus

### 5.4.3 Gradient

The Gradient function can be selected with the Mastercycler® gradient only.

The Gradient function can be used to vary the temperature distribution across the block.

In every temperature step, the thermoblock can be programmed so that each of the 12 columns has a different temperature. The lowest temperature is in the cavities on the left-hand side. It then rises gradually across the block so that the highest temperature is on the right-hand side.

**Show Gradient** The "Show Gradient" menu can be used to show which temperature is in which column:

OPTIONS	Show Gradient		
Editor	Tube: 0.2 ml	T=60.0	G=7.0 °C
Printer			
Gradient			
GENERAL . .			
STANDARD			
--/22.0°			10:22:06

The tube type "0.2 ml, 0.5 ml, 0.5 ml thin, plate" is selected by  and confirmed by pressing .

After a temperature and a gradient have been entered, the temperature distribution across the block appears in the display:

OPTIONS	Show Gradient		
Editor	Settings:	Tube: 0.2 ml	T=60.0C G= 7.0C
Printer	Pos. 1: 52.9C	Pos. 5: 56.9C	Pos. 9: 64.3C
Gradient	Pos. 2: 53.2C	Pos. 6: 58.7C	Pos:10: 65.8C
GENERAL . .	Pos. 3: 54.0C	Pos. 7: 60.6C	Pos.11: 66.9C
STANDARD	Pos. 4: 55.2C	Pos. 8: 62.5C	Pos.12: 67.5C
--/22.0°		Print Results <OPT>	10:22:06

The gradient may be a maximum of  $\pm 10$  °C with a resolution of 0.1 °C. This means that the overall temperature span is 20 °C. The selected temperature is in the middle of the block.

The left-hand side is temperature-controlled to nominal temperature – gradient

The right-hand side is temperature-controlled to nominal temperature + gradient.

## 5 Description of menus

### 5.4.4 GENERAL

To enter general settings and to test the device.

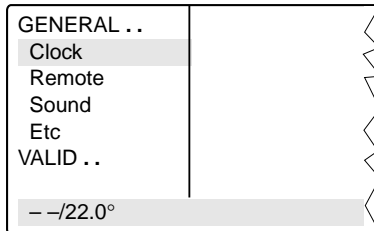

**Clock**      Format:      The time in the 24-(military) or 12-hour-clock format (choice of PM or AM) can be selected using the **Set** key.

Time:      To enter the current time in hours:minutes:seconds.

Date:      To enter the current date as day/month/year.  
The month can be selected using the **Set** key.

**Remote**      Baud rate:      The transmission rate of 19,200, 9,600, 4,800, 2,400 or 1,200 for a PC connection can be selected using the **Set** key.

**Sound**      KeyClick:      ON:      Every keyclick is confirmed by an acoustic signal.  
OFF:      The acoustic signal for keyclicks is switched off.

Warnings:      ON:      In addition to the warning text, warnings are acknowledged by an acoustic signal.  
OFF:      No acoustic signal is emitted to acknowledge a warning.

**Note:** Errors are always acknowledged by an acoustic signal, irrespective of this setting.

**Etc**      Start with:      MAIN:      After the device has been switched on, the main menu appears in the display.  
LAST:      After the device has been switched on, the most-recently used menu appears in the display.

Auto Restart:      YES:      In the event of a power failure, an active program continues when the power supply is restored within three minutes. The time and the stage at which the program was interrupted appear in the display:

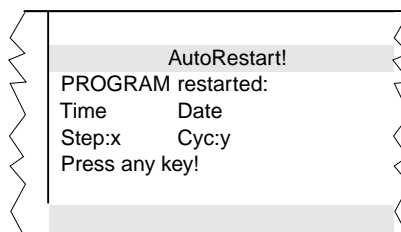

When any key is pressed, the program continues from the point at which it was interrupted. If the program is to be cancelled, press the **Start Stop** key and confirm by pressing **Enter**.

NO:      In the event of a power failure, an active program is cancelled.

## 5 Description of menus

- VALID . .** These programs can be used to test the device. The measurements can be documented by connecting a printer to the device.  
The "Validate" and "Calibrate" menus require the temperature-validation system (order no.: 5331 222.005). This system consists of a special temperature sensor and a personal card with the corresponding software.  
For more detailed information on operating the "Validate" and "Calibrate" programs, see the operating manual for the temperature-validation system.
- Test:** This program can be used to monitor the thermal and electrical functions of the built-in heating and cooling elements (see Sec. 12.2).
- Validate:** To check the device temperature with the aid of a temperature-measuring device. This measuring device forms part of the temperature-validation system and is connected via the serial interface of the Mastercycler.
- Calibrate:** To align the device temperature with the aid of a temperature-measuring device. This measuring device forms part of the temperature-validation system and is connected via the serial interface of the Mastercycler.

## 5 Description of menus

### 5.5 Lid

The "Lid" menu in the main menu can be used to determine the temperature of the heated lid and to switch the heated lid on or off (e.g. to preheat the lid).

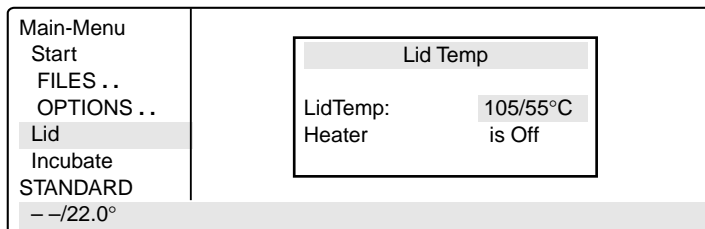

LidTemp: Nominal/actual temperature. To enter the temperature for the heated lid. The lid heating switches off when a temperature value of 0 °C is entered.

Heater is On: Lid heating is on.

Heater is Off: Lid heating is off.

When sensitive PCRs are carried out, it may be important to delay the start until the lid temperature has prevented condensation. This can be achieved by programming the "WAIT" setting, which means that the program does not start until the lid reaches the specified temperature.

In addition, the lid can also be preheated. After the device has been switched on, the "Lid" menu is selected, the desired lid temperature is entered and "Heater is On" is selected by pressing the  key.

When a program starts, it is the program settings which have priority.

When a program is running, the lid heating cannot be switched on or off.

## 5 Description of menus

### 5.6 Incubate

The "Incubate" menu in the main menu is used to determine the block temperature and to switch on/off the temperature control of the block. (e.g. for incubation experiments or to preheat the block). The temperature of the heated lid is aligned to that of the block.

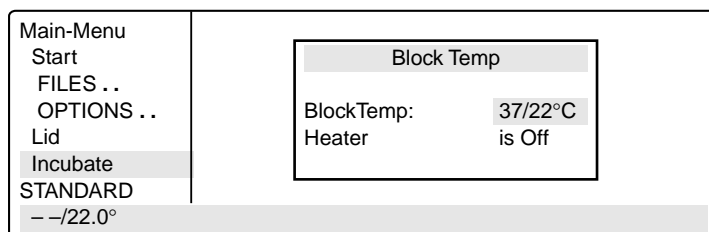

**BlockTemp:** Nominal/actual temperature. To enter the temperature for the thermoblock. It is possible to enter values from +4 °C to 99 °C. It is not possible to select a gradient.

**Heater is On:** Temperature control of the block is on.

**Heater is Off:** Temperature control of the block is off.

Another option is to reduce the program run time if the thermoblock and the heated lid have reached the required temperature before the program starts.

To bring the thermoblock and the heated lid to the desired temperature, select the "Incubate" menu after the device has been switched on, enter the desired block temperature and select "Heater is On" using the **[Sel]** key.

If "Incubate" is running, the "Lid" menu cannot be selected.

When a program starts, it is the program settings which have priority.

When a program is running, the temperature control of the block cannot be switched on or off.

To interrupt: If "Heater is On" is in the display, set the device to "Heater is Off" using the **[Sel]** key and confirm by pressing **[Enter]**.

**Caution:** If the "Incubate" menu has been selected, the thermoblock and the heated lid may be hot when the tubes are inserted, which means that there is a high burns risk for the user.

## 6 Operation

### 6.1 Preparation

#### 6.1.1 Loading the samples

The thermoblock can be loaded with three different types of tubes without needing to be exchanged. It can accommodate 96 PCR test tubes of 0.2 ml or 77 thin-walled PCR test tubes of 0.5 ml (special tube from Eppendorf) or 1 microtiter plate (8x12).

To achieve optimal temperature transition, only sample tubes and microtiter plates with a V-shaped base should be used (see "Ordering information"). Test tubes must fit tightly into the thermoblock and should not wobble or move in any way. Tubes which are not sufficiently temperature-stable (up to approx. 120 °C) should not be used.

In general, this also applies to foils used to seal microtiter plates. However, due to the temperature-controlled lid heating, it is also possible to use foils which would melt above 100 °C. In this case, the lid heating can be set, for example, to 95 °C.

The thermoblock has 96 narrow positions for 0.2 ml test tubes and microtiter plates and 77 wide positions for 0.5 ml test tubes. To enable the maximum possible number of 0.5 ml test tubes to be inserted into the thermoblock, the tubes must be positioned in rows. In addition, in order to ensure that the heated lid is closed evenly, it is strongly recommended to position a tube in each corner of the thermoblock. Loading should be carried out as follows:

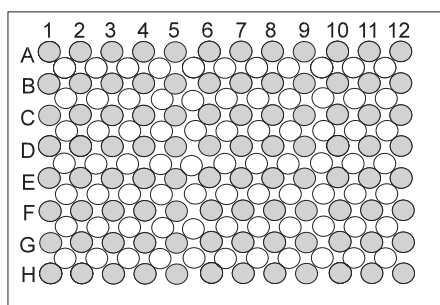

96 x 0.2 ml PCR test tubes  
or  
microtiter plates (8x12)  
(PCR plate 96)

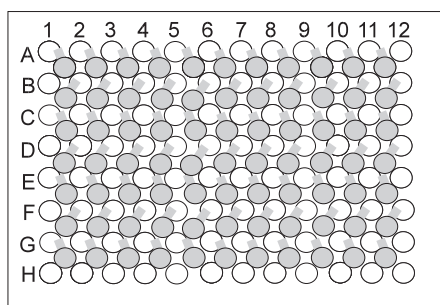

77 x 0.5 ml thin-walled PCR test tubes  
(special tube from Eppendorf)

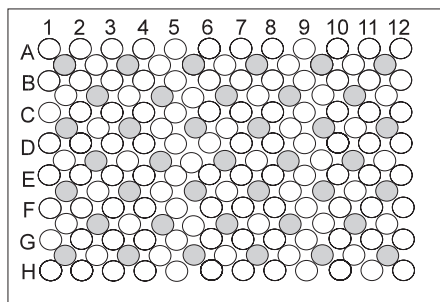

39 x 0.5 ml Eppendorf Safe-Lock micro test tubes  
  
0.5 ml test tubes with wide lid  
(e.g. 0.5 ml Eppendorf micro test tubes)  
should be loaded in a staggered way

*in situ* reactions require the *in situ* Adapter. With the aid of the "pegs" on the base, the metal carrier for a maximum of four glass slides is inserted into the 0.5 ml positions of the thermoblock.

## 6 Operation

### 6.1.2 Sample volume

Temperature control can be set to thermoblock or to sample.

The device can adapt to the actual sample quantity and test tube type via the command "CNTRL /TUBE". For maximum flexibility, the program will prompt for tube sizes and volumes when it is started.

The following sample quantities should be used:

0.2 ml test tubes or "plate": not larger than 50  $\mu$ l

0.5 ml or 0.5 ml thin-walled test tubes: not larger than 100  $\mu$ l

When "*in situ*" is selected, the sample quantity is not taken into consideration.

### 6.1.3 Heated lid

After the samples have been loaded, the heated lid is closed over the thermoblock and locked using the locking lever in accordance with the type of tube used.

**Note:** Some types of PCR plates lock into position at the 0.2 ml tube level. Do not force the locking lever when this happens.

Since the heated lid prevents the liquid from condensing in the upper part of the tube, it is not necessary to use an oil layer.

**Note:** Different tube types should not be loaded together as they cannot be sealed correctly by the heated lid. If it is absolutely necessary to process different tube types simultaneously in the thermoblock, an oil layer is necessary for the smaller tubes.

The lid temperature (up to 110 °C) is controlled automatically by the program. The user can decide whether the program should start immediately (NOWAIT) or whether it should start after a preset lid temperature has been attained (WAIT). If the program has to start quickly, the heated lid can be preheated using the "Lid" menu.

All tubes are easily accessible during the temperature-control procedure since the lid can be opened at any time.

**Caution:** To avoid the risk of burns (110 °C) caused by touching the inner surface of the lid or the thermoblock, do not open the lid while the program is running. Depending on the processing temperatures used, test tubes and microtiter plates may also be extremely hot. During *in situ* reactions, the heated lid is not temperature-controlled and remains open at all times.

### 6.1.4 Temperature-control of the block

To carry out incubation experiments or to speed up the start of a method, it is possible to preheat the thermoblock and the heated lid. The "Incubate" menu is selected in the main menu, a block temperature is entered and "Heater" is set to "on".

**Caution:** Since the thermoblock and the heated lid can become very hot, there is a burns risk for the user when test tubes and microtiter plates are inserted.

# 6 Operation

## 6.2 Switching on the device

- Switch on the device using the main power switch on the rear of the device.

The current software version appears briefly in the display. The main menu then appears.

Main-Menu	
Start	*** MASTERCYCLER ***
FILES ..	gradient 5331
OPTIONS ..	eppendorf
Lid	Version *.*.*
Incubate	
STANDARD	
--/25.0°	Lid:105° 10:22:06

The program which is ready to be started appears in the processing level.

Main-Menu	
Start	
FILES ..	
OPTIONS ..	
Lid	
Incubate	
STANDARD	
--/25.0°	Lid:105° 10:22:06



## 6.3 Starting a program

- The program in the processing level can be started immediately by pressing the  key.

To start another program,

- press .

A list of the programs appears in the display.

- Select the program name using the  or  key (the program name appears with a dark background).

The procedure for starting programs which are stored on a personal card is described in Sec. 9.3.

Main-Menu	Run a Program:
Start	STANDARD
FILES ..	TEST1
OPTIONS ..	TEST2
Lid	
Incubate	
STANDARD	
--/25.0°	Lid:105° 10:22:06

- Press .

The program starts immediately after a "Testing Program".

Main-Menu	Run a Program:
Start	1 T=95.0° 0:00:05
FILES ..	
OPTIONS ..	
Lid	
Incubate	
Running/STANDARD	Cyc:4
95.0/94.7°	Lid:105° 10:22:06



## 6 Operation

If the program contains the "CNTRL/TUBE" command (temperature control set to sample), it is necessary to enter the tube type and the filling volume after the program has started.

- Select the tube type: 0.2 ml, 0.5 ml (e.g. Safe-Lock), 0.5 ml thin (thin-walled tubes), plate (microtiter plate) or *in situ* using the **sel** key and confirm by pressing **Enter**.

Main-Menu	Run a Program:	
Start	CNTRL	TUBE
FILES ..	Tube: 0.2 ml	
OPTIONS ..		
Lid		
Incubate		
Enter Tube		
22.0/25.0°	Lid:105°	10:22:06

- Enter the filling volume and confirm by pressing **Enter**.

Tube type 0.2 ml/plate: 5 to 50 µl  
 Tube type 0.5 ml/thin: 5 to 100 µl  
*in situ*: no entry necessary

If no entries are made for "Tube" and "Fill.Vol.", the program will not run. "EnterTube" appears in the main menu instead of the program name and a long acoustic signal is emitted until the entry is made.

Main-Menu	Run a Program:	
Start	CNTRL	TUBE
FILES ..	Fill.Vol.: 20 µl	
OPTIONS ..		
Lid		
Incubate		
STANDARD		
22.0/25.0°	Lid:105°	10:22:06

After the start of the program and while it is running, the name of the program appears in the main menu in alternation with "Running".

A flashing temperature display indicates that the nominal temperature has not been attained and that heating/cooling is currently taking place.

Main-Menu	Run a Program:	
Start	1	T=95.0° 0:00:05
FILES ..		
OPTIONS ..		
Lid		
Incubate		
Running/STANDARD	Cyc:4	
95.0/97.0°	Lid:105°	10:22:06

1 2 3 4 5 6

- The display of a program can be exited at any time (e.g. to program in the "Edit" processing level) by pressing **Exit**.

- 1 Program flashes in alternation with "Running"
- 2 Nominal/actual block temperature
- 3 Lid temperature (only when lid is switched on)
- 4 Program line number, program command  
Example: Temperature command (T) with nominal temperature and cycle length
- 5 Number of completed cycles
- 6 Time

# 6 Operation

## 6.4 Displaying the running time of a program

While a program is running, the approximate run time and the expected end time of the program can be shown in the display.

- Press **Opt**.

The key is effective only when a program run appears in the display, not in the main menu, with other menus or sub-menus.

Main-Menu	Run a Program:	
Start	Run Time:	1:03
FILES ..	Finish Time:	17/Jun/1997 15:06
OPTIONS ..		
Lid		
Incubate		
Running/STANDARD		Cyc:4
22.0/25.0°	Lid:105°	14:02:30

Program end
Current time  
 Run time in hours:minutes

## 6.5 Interrupting a program

A program can be aborted, paused or continued at any point by pressing **Start/Stop**.

- Press **Start/Stop**.

Using the **Sel** key, select between:

- Stop To abort the program
- Pause To interrupt the program
- Run To return to the display of the program sequence

Main-Menu	Run a Program:	
Start	STANDARD running...	
FILES ..	Program: STOP	
OPTIONS ..		
Lid		
Incubate		
Running/STANDARD		
95.0/94.5°	Lid:105°	10:22:06

- Using the **Sel** key, move to "Pause".
- Confirm "Program:PAUSE" by pressing **Enter**.

The program is interrupted, time counting stops and the last nominal temperature is retained.



Main-Menu	Run a Program:	
STOP !	STANDARD running...	
FILES ..	Program: PAUSE	
OPTIONS ..		
Lid		
Incubate		
Paused/STANDARD		
95.0/94.5°	Lid:105°	10:22:06

The name of the interrupted program appears in the main menu in alternation with "Paused" and the "Start" menu changes to the display "Stop".

# 6 Operation

## 6.6 Continuing an interrupted program

The name of the program appears in the display in alternation with "Paused"

- Press  .
- Using the  key, select between:
  - Stop To abort the program
  - Pause To interrupt the program
  - Resume To continue the program
- Using the  key, move to "Resume".

Main-Menu	Run a Program:
STOP !	STANDARD PAUSED
FILES ..	Program: PAUSE
OPTIONS ..	
Lid	
Incubate	
Paused/STANDARD	
95.0/94.5°	Lid:105° 10:22:06

- Confirm "Program:RESUME" by pressing  ; the program is continued.

Main-Menu	Run a Program:
STOP !	STANDARD PAUSED
FILES ..	Program: RESUME
OPTIONS ..	
Lid	
Incubate	
Paused/STANDARD	
95.0/94.5°	Lid:105° 10:22:06

## 6.7 Aborting a program

- Press  .
- Confirm "Program:STOP" by pressing  .

Main-Menu	Run a Program:
STOP !	STANDARD running...
FILES ..	Program: STOP
OPTIONS ..	
Lid	
Incubate	
Paused/STANDARD	
95.0/94.5°	Lid:105° 10:22:06

## 6.8 Switching off the device

After a program has been completed, the following appears in the display:

Main-Menu	Run a Program:
Start	End of program
FILES ..	
OPTIONS ..	
Lid	
Incubate	
STANDARD	
22.0/25.0°	Lid:105° 14:02:30

If a new program has to be started, exit the old program by pressing  .

To switch off the device, move the main power switch on the rear of the device to  .

# 7 Programming

## 7.1 Command description

A program contains two basic commands for controlling the temperature of the thermoblock and of the heated lid as well as six different commands for programming.

A program can contain up to 40 program lines. The commands may be repeated as desired.

Digits or letters may be entered or selections are made using the Sel key.

When digits are entered, the message "Value out of range" appears when values are entered which are not within the given specifications. The permitted limit value is then entered automatically.

FILES...	Edit UNNAMED		
Edit	CNTRL		BLOCK
Load	LID=0°		
Standard	NOWAIT		AUTO
New			
Delete			
UNNAMED			
-----			
	1	T=****° +0.0° R=3.0°/s G=0.0°	***:*** +0:00 +0.0°/s
	2	Hold ****°	ENTER
	3	PAUSE PRESS	ENTER
	4	GOTO***	REP***
	5	SOUND**	
	6	LINK*****	
		end	
--/22.0°	10:22:06		

### 7.1.1 CNTRL

With this command is determined the type of temperature control for the block.

**BLOCK** The temperature is measured on the thermoblock and the nominal temperature is then set.

**TUBE** The software adapts the temperature of the thermoblock to the temperature of the tubes and the sample quantity. For this reason, the tube type and the filling volume must be entered immediately after the start of the program. No further entries are necessary when *in situ* is selected.

Tube type 0.2 ml or plate: 5 to 50 µl filling volume  
0.5 ml or 0.5 ml thin: 5 to 100 µl filling volume

# 7 Programming

## 7.1.2 Lid

To determine the temperature of the heated lid. If 0 °C is selected, the heated lid remains switched off.

Permitted values	0 to 110 °C
Entry increments	1 °C

In addition to the entry for the temperature of the heated lid, it is also possible to determine the behavior of the lid temperature at the start and at the end of a program:

### At the start

**NOWAIT** The program is started, independent of the lid temperature.

**WAIT** The program is not started until the programmed lid temperature has been attained.  
**Note:** To accelerate the start of the program, the lid may be preheated using the "Lid" menu.

### At the end

**FIX** The lid temperature does not depend on the block temperature. The lid heating is switched off at the end of the program.

**AUTO** The lid temperature depends on the block temperature. If 22 °C is maintained for longer than five minutes, the lid heating switches off; this is also applicable in the case of a Hold command at temperatures < 22 °C.

The six commands for programming can be called up directly using the allotted number.

## 7.1.3 T Selection also possible using 1

To enter the temperature and the cycle time as well as the accompanying specific options.

The options are entered by positioning the cursor on the program line number and pressing the Opt key.

The options may be entered for every temperature command.

<b>T = ****°</b>	<b>**:**:**</b>	Nominal temperature, cycle time
<b>+ 0.0 °</b>	<b>+ 0:00</b>	Temperature increment, time increment
<b>R = 3 °/s</b>	<b>+ 0.0 °/s</b>	Ramp, ramp increment
<b>G = 0.0</b>		Gradient (for Mastercycler® gradient only)

**T = \*\*\*\*°** The nominal temperature is entered in degrees Celsius (°C).

Permitted values	4 to 99.0 °C
Entry increments	0.1 °C

**\*\*':\*\*':\*\*** The cycle time is entered in "hours:minutes:seconds".

Permitted values	0:00:01 to 9:59:59
Entry increments	1 s

## 7 Programming

**+ 0.0 °** Temperature increment ( $\pm$  °C): For each cycle, the temperature is increased or decreased by the value entered here.

Please note that the temperature cannot exceed 99 °C. For example, with a temperature increment of +0.1 °C and 25 cycles, the starting temperature cannot be greater than 96.5 °C.

Entry for temperature increase	"+"
Entry for temperature decrease	" - "
Permitted values	$\pm 0.0$ to $\pm 10.0$ °C
Entry increments	0.1 °C

**+ 0:00** Time increment ( $\pm$  s): For each cycle, the time is extended or reduced by the value entered here.

Entry for time extension	"+"
Entry for time reduction	" - "
Permitted values	0:01 to 1:00
Entry increments	1 s

**R = 3 °/s** Ramp (°C/s): The ramp states the speed of the heating or cooling curve of a cycler. The higher the value entered, the more rapidly the heating or cooling takes place. Most reactions require rapid heating or cooling rates, i.e. a high value. For processes in which heating or cooling should take place slowly, different values may be entered for the ramp.

Permitted values	0.3 to 3 °C/s
Entry increments	0.1 °C/s

**+ 0.0 °/s** Ramp increment ( $\pm$  s): For each cycle, the ramp is raised or lowered by the value entered here. Please note that the ramp cannot exceed 3 °C/s, i.e. with an initial ramp entry of 0.3 and a ramp increment of 0.1, a maximum of 27 cycles is possible.

Permitted values	$\pm 0.1$ to $\pm 1.0$ °C/s
Entry increments	0.1 °C/s

**G = 0.0** Possible with Mastercycler® gradient only.  
Gradient: When an entry is made here, each column of the block is set to a different temperature. The nominal temperature set at "T" is in the center of the block. The lowest temperature is on the left-hand side and increases gradually up to the highest temperature on the right-hand side. This means that a temperature difference of up to 20 °C across the block can be generated (see Sec. 5.4.3). The temperature distribution can be viewed in the OPTIONS/Gradient program. With 0.2 ml test tubes, a maximum of 12 different temperatures may be set whereas only 11 can be set when 0.5 ml test tubes are used.

Please note that the temperature cannot exceed 99 °C, i.e. if a gradient of +10 °C is built up, the nominal temperature may not be greater than 89 °C.

Permitted values	$\pm 10$ °C
Entry increments	0.1 °C

The gradient has no effect when the "in situ" type is used.

# 7 Programming

## 7.1.4 HOLD Selection also possible using 2

The program holds the temperature at the value which was entered. The program is continued or ended by pressing .

**Note:** A program should not begin with a HOLD command and a temperature < 22 °C because the temperature-control for the lid will not start. If, for example, 4 °C is required at the beginning of a program, HOLD should be connected to the main program via a LINK command (see Sec. 7.6, "Examples of programming").

### **HOLD xx ENTER**

Permitted values	4 to 99 °C
Entry increments	0.1 °C

## 7.1.5 PAUSE Selection also possible using 3

The program is interrupted and the temperature remains at the value for the last temperature command. The program is continued by pressing .

A user-defined text may be entered instead of the preset text "PRESS ENTER".

### **PAUSE PRESS ENTER**

Text length	0 to 11 characters
-------------	--------------------

## 7.1.6 GOTO Selection also possible using 4

To enter data for cycle repeats. It is possible to branch to another program line number (GOTO) where the program should be continued. The number of times this should be carried out (REP) is also given.

### **GOTO xxx REP xxx**

Permitted values	
Program line number	1 to 40
Repeats	1 to 99

## 7.1.7 SOUND Selection also possible using 5

To emit an acoustic signal (e.g. for displaying a programmed pause or when a program is ended).

### **SOUND \*\***

Permitted repeats	1 to 10 tones
-------------------	---------------

## 7.1.8 LINK Selection also possible using 6

To link up with another program in the internal memory. Via the LINK command, the current program is ended and the selected program is started. With the aid of LINK commands, a maximum of five programs may be run in succession. The CNTRL, Lid, NOWAIT/WAIT, AUTO/FIX commands in the program head are not taken into consideration during the subsequent programs.

It is not possible to branch to programs in the processing level ("Edit") or on the personal card using LINK commands (it is possible from the personal card to programs in the internal memory).

### **LINK \*\*\*\*\***

Permitted number of programs	5
------------------------------	---

The name of the program to be called up must be entered (select letters using the  key). If the name of the program itself is entered, the program goes into an endless loop and can only be cancelled by pressing "Stop".

# 7 Programming

## 7.1.9 END

END appears automatically as the last line of a program. It switches off the temperature control for the block and for the lid.

## 7.2 Creating a new program

The process for entering program commands is identical for the Mastercycler<sup>®</sup> and the Mastercycler<sup>®</sup> gradient. A gradient can also be programmed with the Mastercycler<sup>®</sup> gradient.

Example for a program sequence:

Initial denaturation 95 °C for 2 minutes

20 cycles:

Denaturation 95 °C for 45 seconds

Annealing 61 °C for 45 seconds with a temperature increment of -1 °C

A gradient of  $\pm 10$  °C is programmed (with Mastercycler<sup>®</sup> gradient only)

Elongation 72 °C for 45 seconds

Final elongation 72 °C for 2 minutes

Cooling of samples 22 °C

When the gradient is set at 61 °C  $\pm$  10 °C when 12 x 0.2 ml test tubes are used, the temperature distribution in the individual columns of the thermoclock is as follows:

Tube row	1	2	3	4	5	6	7	8	9	10	11	12
Temperature	51.0	51.3	52.5	54.2	56.5	59.1	61.8	64.5	67.0	69.1	70.6	71.5

When 0.5 ml test tubes are used, the 11 rows of the block have the following temperatures:

Tube row	1	2	3	4	5	6	7	8	9	10	11
Temperature	51.1	51.9	53.3	55.4	57.8	60.5	63.2	65.8	68.1	69.9	71.1



# 7 Programming

## 7.2.1 Programming

- Select the "FILES" menu using the  $\blacktriangledown$  or  $\blacktriangle$  key and call up by pressing .

Main-Menu	
Start	
FILES ..	
OPTIONS ..	
Lid	
Incubate	
STANDARD	
--/22.0°	10:22:06

- Select the "New" menu using the  $\blacktriangledown$  or  $\blacktriangle$  key and call up by pressing .

FILES ..	Edit UNNAMED
Edit	CNTRL BLOCK
Load	LID=0°
Standard	NOWAIT AUTO
New	end
Delete	
UNNAMED	
--/22.0°	10:22:06

### CNTRL BLOCK

- Using the  key or confirm by pressing .

### LID=105° NOWAIT AUTO

- Enter the values and press the , ,  keys. Change "Nowait" and "Auto" ( key) or confirm by pressing .

FILES ..	Edit UNNAMED
Edit	CNTRL BLOCK
Load	LID=105°
Standard	NOWAIT AUTO
New	end
Delete	
UNNAMED	
--/22.0°	10:22:06

### Initial denaturation

#### T=95.0° 0:02:00

- Select command T (Temperature) using the  key (it may be necessary to press the key several times) and confirm by pressing .

FILES ..	Edit UNNAMED
Edit	CNTRL BLOCK
Load	LID=105°
Standard	NOWAIT AUTO
New	1 T=****° **:*:**
Delete	end
UNNAMED	
--/22.0°	10:22:06

- Enter the temperature, press the ,  keys and confirm by pressing .

FILES ..	Edit UNNAMED
Edit	CNTRL BLOCK
Load	LID=105°
Standard	NOWAIT AUTO
New	1 T=95.0° **:*:**
Delete	end
UNNAMED	
--/22.0°	10:22:06

- Enter the time (seconds:minutes:hours). Press the , ,  keys and confirm by pressing .

FILES ..	Edit UNNAMED
Edit	CNTRL BLOCK
Load	LID=105°
Standard	NOWAIT AUTO
New	1 T=95.0° 00:02:00
Delete	end
UNNAMED	
--/22.0°	10:22:06

# 7 Programming

## Denaturation

**T=95.0° 0:00:45**

Programming: see page 30.

## Annealing

**T=61.0° 0:00:45**

- Press the **Opt** key for options for the temperature command (temperature- and time increment, ramp, ramp increment, gradient).

The cursor must be on the program line number in front of the temperature command.

FILES ..	Edit UNNAMED		
Edit		Lid 105°	
Load		NOWAIT	AUTO
Standard	1	T= 95.0°	0:02:00
New	2	T= 95.0°	0:00:45
Delete	3	T= 61.0°	0:00:45
UNNAMED		+ 0.0	+0:00
– /22.0°	10:22:06		

- Press the **6**, **1** keys and confirm by pressing **Enter**.
- Press the **4**, **5** keys and confirm by pressing **Enter**.
- Press **Enter** to proceed to Gradient or Elongation.

## Gradient

**Possible with Mastercycler® gradient only.**

**G=10.0°**

- Enter the gradient, press the **1**, **0** keys and confirm by pressing **Enter**.

FILES ..	Edit UNNAMED		
Edit	1	T= 95.0°	0:02:00
Load	2	T= 95.0°	0:00:45
Standard	3	T= 61.0°	0:00:45
New		+ 0.0	+0:00
Delete		R= 3.0°/s	+0:0°/s
UNNAMED		G= 10.0°	
– /22.0°	10:22:06		

## Elongation

**T=72.0° 0:00:45**

Select the command T.

- Press the **7**, **2** keys and confirm by pressing **Enter**.
- Press the **4**, **5** keys and confirm by pressing **Enter**.

FILES ..	Edit UNNAMED		
Edit	2	T= 95.0°	0:00:45
Load	3	T= 61.0°	0:00:45
Standard		+ 0.0	+0:00
New		R= 3.0°/s	+0:0
Delete		G= 10.0°	
UNNAMED	4	T= 72.0°	00:00:45
– /22.0°	10:22:06		

## Cycle

**GOTO 2 REP 19**

- Select the GOTO command using the **Sel** key (it may be necessary to press the key several times) Confirm by pressing **Enter**.
- Enter the line number for the beginning of the program section which is to be repeated. Confirm by pressing **Enter**. Enter the number of repeats (REP). Confirm by pressing **Enter**.

**Note:** The total number of cycles is REP + 1.

FILES ..	Edit UNNAMED		
Edit	3	T= 61.0°	0:00:45
Load		+ 0.0	+0:00
Standard		R= 3.0°/s	+0:0
New		G= 10.0°	
Delete	4	T= 72.0°	00:00:45
UNNAMED	5	GOTO***	REP***
– /22.0°	10:22:06		

# 7 Programming

## Final elongation

**T=72.0° 0:02:00**

Programming see page 30.

FILES . .	Edit UNNAMED		
Edit		+ 0.0	+0:00
Load		R= 3.0%/s	+0:0
Standard		G= 10.0°	
New	4	T= 72.0°	00:00:45
Delete	5	GOTO 2	REP 19
UNNAMED	6	T= 72.0°	00:02:00
--/22.0°	10:22:06		

## Cooling of samples

**HOLD 22.0° ENTER**

- Select the HOLD command using the  key (it may be necessary to press the key several times) and confirm by pressing .
- Enter the temperature. Confirm by pressing .

FILES . .	Edit UNNAMED		
Edit		R= 3.0%/s	+0:0
Load		G= 10.0°	
Standard	4	T= 72.0°	00:00:45
New	5	GOTO 2	REP 19
Delete	6	T= 72.0°	00:02:00
UNNAMED	7	Hold 22.0°	ENTER
--/22.0°	10:22:06		

### 7.2.2 Saving a program

- Exit the "New" menu using the  key.
- To save, press the  key; the device asks for the program name.

FILES . .	Edit UNNAMED		
Edit	UNNAMED not saved		
Load	SAVE: YES		
Standard	ProgName: UNNAMED		
New			
Delete			
UNNAMED			
--/22.0°	10:22:06		

In the case of a new program, the device suggests the name "UNNAMED".

- Confirm the name by pressing  or – if an other name is desired – delete by pressing  (if the key is held down, the entire name is deleted; if the keys is pressed briefly, individual letters only are deleted).
- Enter the new program name. Select letters using the  key. Press the  key to move to the next position etc. and confirm by pressing .

FILES . .	Edit UNNAMED		
Edit	UNNAMED not saved		
Load	SAVE: YES		
Standard	ProgName: Gradient		
New			
Delete			
UNNAMED			
--/22.0°	10:22:06		

If the program is to be saved under an existing name, the question appears:

# 7 Programming

- "Overwrite:YES"  
Confirm overwriting by pressing .

If you do not want to overwrite the existing program, select "NO" using the  key, press  and enter a new name. Confirm the new name by pressing .

FILES ..	Edit UNNAMED
Edit	Testing...
Load	Gradient exists
Standard	Overwrite: YES
New	
Delete	
UNNAMED	
--/22.0°	10:22:06

If a program is not saved ("Save:NO"), it remains in the processing level and can be supplemented or modified by calling up "Edit". Safety checks in other sub-items prevent a program which has not been saved from being accidentally overwritten.

The internal memory can accommodate a maximum of 99 programs. The number possible depends on the length of the programs.

The program in the processing level can be started by pressing the  key.

**Note:** The procedure for saving programs on a personal card is described in Sec. 9.3.

## 7.3 Modifying a program

A program which is already in the internal memory or on a personal card can be modified by being loaded into the processing level. The program resident in the "Edit" processing level is thus deleted. If a program which has not yet been saved is in the processing level, it can be saved following a safety check prior to deletion.

- Select the "FILES" menu using the  or  key and confirm by pressing .

Main-Menu	
Start	
FILES ..	
OPTIONS...	
Lid	
Incubate	
STANDARD	
--/22.0°	10:22:06

- Select the "Load" menu using the  or  key and call up by pressing .

A list of existing programs appears in the display.





FILES ..	Load to Editor
Edit	STANDARD
Load	TEST1
Standard	TEST2
New	
Delete	
STANDARD	
--/22.0°	10:22:06

- Select the program using the  or  key and load by pressing .



FILES...	Edit STANDARD		
Edit	1	T= 94.0°	0:02:00
Load	2	T= 94.0°	0:00:15
Standard	3	T= 44.0°	0:00:15
New	4	T= 72.0°	0:00:30
Delete		+ 0.0°	+0:01
STANDARD		R= 3.0°/s	+0:0°/s
--/22.0°	10:22:06		

# 7 Programming

## Changing the program line







- Using the  /  keys, move the flashing cursor onto the parameter which is to be changed.
- Enter data using the digit block or select between settings using the  key or enter letters using the  key.

## Inserting a program line







- Move the flashing cursor in front of the line. The cursor must be positioned on the program line number.
- Press the  key. A new line is inserted **above** the cursor.
- Select the command using the  key.

**Note:** Press the  key for options regarding the temperature command. In this case, the cursor must be positioned on the program line number in front of the temperature command.

## Deleting a program line

- Move the flashing cursor to the program line number.
- Press the  key. The line is deleted.
- After a program has been changed, exit the "Edit" processing level by pressing the  key.
- Confirm the safety check "Save:YES" by pressing .
- The program can be saved using the same name. Confirm the check "Overwrite:YES" by pressing .
- If the program should not be overwritten, and a new program is to be created, answer "Overwrite:" with "NO" ( and  keys) and enter a new program name.

## Changing and checking programs

- Load the program that is to be changed / checked ("Load" menu; the program name must be in the bottom left in the processing level).
- Change the program.
- Exit the program using the  key. "Program not saved – Save YES" appears in the display. Either save the program or exit by pressing .
- **Caution:** If the changed program is not stored under a new name, there will be two different programs with the same name. The program which has been changed is in the processing level and the program which has not been changed is in the device memory.
- Start the program: Press the  key. The program which has been changed starts running.
- Program end: "End of Program" appears in the display. Press the  key.
- If you now want to save the program which has been changed, select the "Load" menu and press .
- "Program not saved – Save YES" appears in the display.
- Save the program: Press .

# 7 Programming

## 7.4 Creating programs using an example program

It is possible to program quickly with the aid of the "Standard" example program. A program does not need to be completely rewritten; the sample can be supplemented, modified and then saved under a new name.

- Select the "FILES" menu and call up by pressing .
- Select "Standard" and call up by pressing .

The example program is loaded into the processing level. It is structured in the following way:

CNTRL	BLOCK	Temperature control for the block.	
LID=105°		Sets heated lid to 105 °C.	
NOWAIT	AUTO	NOWAIT = Program is started immediately. AUTO = Lid heating is switched off automatically when temperature (22 °C) is maintained for more than 5 minutes.	
1	T=94.0°	0:02:00	Maintains 94 °C for 2 min. (initial denaturation)
2	T=94.0°	0:00:15	Maintains 94 °C for 15 secs. (denaturation)
3	T=44.0°	0:00:15	Maintains 44 °C for 15 secs. (annealing)
4	T=72.0°	0:00:30	Maintains 72 °C for 30 secs. (elongation)
5	GOTO 2	REP 24	Repeats 24 times from program step 2 onwards. The total number of cycles is 25.
6	T=72.0°	0:00:30	Maintains 72 °C for 30 secs. (final elongation)
7	HOLD 22.0°	ENTER	Cools down to 22 °C and maintains temperature.
	end		Program end

Although the example program cannot be deleted, individual changes can be made. After changes have been made, the example program must be saved under the name "Standard". To restore the original example program, the "Standard" program in the "Delete" sub-menu must be deleted. When "Standard" is called up, the original example program is reloaded into the processing level.

## 7.5 Deleting a program

- Select the "FILES" menu and call up by pressing .
- Select "Delete" and call up by pressing .

A list of the existing programs appears in the display.

FILES ..	Delete Program
Edit	TEST 1
Load	TEST 2
Standard	
New	
Delete	
STANDARD	
- /22.0°	10:22:06

- Select the program name.
- Confirm by pressing . The program is deleted.

The procedure for deleting programs on a personal card is described in Sec. 9.3.

# 7 Programming

## 7.6 Examples of programming

The following passage contains several examples of the versatility of the commands and functions of the Mastercyclers.

### 7.6.1 Gradient PCR (for Mastercycler® gradient only)

The Gradient PCR is used to optimize temperatures in a PCR experiment. The gradient may be programmed with a temperature range of up to 20 °C with every temperature command.

The most common application is the determination of the optimal annealing temperature (see example), for which a gradient of, for example,  $\pm 10$  °C is built up. The recommended mean gradient is 5 °C higher than the calculated annealing temperature.

<b>Gradient PCR</b>			
	Temperature control of tubes	Control	tube
	Temperature control of lid	lid	105°
		Nowait	auto
1	Initial denaturation	94°	2 min
2	Denaturation	94°	15 sec
3	Annealing	60°	15 sec
	<b>Gradient</b>	<b>G=10°</b>	
4	Elongation	72°	30 sec
5	Number of cycles	go to 2	Rep 29
6	Final elongation	72°	2 min
7	Cooling and storage	Hold 20°	enter
	End	end	

# 7 Programming

## 7.6.2 Hot Start PCR

The "Pause" command is used to interrupt the program. The most-recently entered temperature is maintained. A text explaining the reason for the interruption may be entered as required. After confirmation by pressing , the program is continued.

The "Hold" command enables all possible temperatures to be maintained until the program is continued by pressing .

In the example of a Hot Start PCR listed below, the program is stopped following initial denaturation in order to add a reaction component. After the final elongation, the block is cooled down to room temperature.

<b>Hot Start PCR</b>			
	Temperature control of tubes	Control	tube
	Temperature control of lid	lid	105°
		Nowait	auto
1	Initial denaturation	94°	2 min
2	<b>Pause for adding substance</b>	<b>Pause</b>	<b>Adding</b>
3	Denaturation	94°	15 sec
4	Annealing	55°	15 sec
5	Elongation	72°	30 sec
6	Number of cycles	go to 3	Rep 29
7	Final elongation	72°	2 min
8	Cooling and storage	Hold 20°	enter
	End	end	



## 7 Programming

### 7.6.3 Touch Down PCR

The temperature increment, which can be programmed as desired with every temperature command, allows the temperature to be reduced or increased by a defined value with every cycle.

Touch Down PCR can be used to increase the specificity of the PCR by changing the the annealing temperature in succession from higher to lower temperatures.

In the example given, the annealing temperature is reduced by 1 °C per cycle for the first 15 cycles, until 50 °C has been attained. At this annealing temperature, 14 additional cycles are carried out.

<b>Touch Down PCR</b>			
	Temperature control of tube	Control	tube
	Temperature control of lid	lid	105°
		Nowait	auto
1	Initial denaturation	94°	2 min
2	Denaturation	94°	15 sec
3	Annealing	65°	15 sec
	<b>Temperature increment</b>	<b>-1°</b>	
4	Elongation	72°	30 sec
5	Number of cycles	go to 2	Rep 15
6	Denaturation	94°	15 sec
7	Annealing	50°	15 sec
8	Elongation	72°	30 sec
9	Number of cycles	go to 6	Rep 13
10	Final elongation	72°	2 min
11	Cooling and storage	Hold 20°	enter
	End	end	

### 7.6.4 Long PCR

The time increment, which can be programmed as desired with every temperature command, enables a defined extension of the lag time at a specific temperature for each cycle.

With Long PCR, this function can be used to amplify long fragments for a successive extension of the elongation.

In the example given, the elongation time is extended by 10 seconds for each cycle, which means that, for the 30th cycle, the elongation time is 290 seconds longer than for the first cycle.

<b>Long PCR</b>			
	Temperature control of tubes	Control	tube
	Temperature control of lid	lid	105°
		Nowait	auto
1	Initial denaturation	94°	2 min
2	Denaturation	94°	15 sec
3	Elongation	68°	10 min
	<b>Time increment</b>		<b>+0:10 sec</b>
4	Number of cycles	go to 2	Rep 29
5	Final elongation	72°	15 min
6	Cooling and storage	Hold 20°	enter
	End	end	

## 7 Programming

### 7.6.5 PCR "Fingerprinting" (RAPD-PCR)

Variable heating and cooling rates, which can be programmed as desired with each temperature command, enable the temperature-control speed to be aligned to the temperature.

With the RAPD-PCR process or with PCR with A/T-rich primer/template hybrids, it may be necessary to heat up carefully after annealing.

In the example given, the elongation temperature is attained at a speed of 1 °C/s.

<b>RAPD-PCR</b>			
	Temperature control of tube	Control	tube
	Temperature control of lid	lid	105°
		Nowait	auto
1	Initial denaturation	94°	2 min
2	Denaturation	94°	15 sec
3	Annealing	55°	15 sec
4	Elongation	72°	30 sec
	<b>Heating rate</b>	<b>R=1°/s</b>	
5	Number of cycles	go to 2	Rep 29
6	Final elongation	72°	2 min
7	Cooling and storage	Hold 20°	enter
	End	end	

Temperature-control speeds, which may be as slow as the user desires, can be selected by means of program loops, with which a gradual change in temperature is obtained via temperature increments.

In the following example, the elongation temperature is raised slowly to 72 °C after annealing with the aid of a program loop.

<b>RAPD-PCR</b>			
	Temperature control of tube	Control	tube
	Temperature control of lid	lid	105°
		Nowait	auto
1	Initial denaturation	94°	2 min
2	Denaturation	94°	15 sec
3	Annealing	55°	15 sec
4	Elongation	56°	7 sec
	<b>Temperature increment</b>	<b>+1°</b>	
	<b>Heating rate</b>	<b>R=0.3°/s</b>	
5	Number of cycles	go to 4	Rep 16
6	Number of cycles	go to 2	Rep 29
7	Final elongation	72°	2 min
8	Cooling and storage	Hold 20°	enter
	End	end	

# 7 Programming

## 7.6.6 Sample cooling and subsequent PCR

If sensitive samples should remain cooled until the PCR takes place, the thermoblock must be preheated. This can be carried out in two ways:

1. Set the "Incu" menu to 4 °C and "Heater is On".
2. Adapt an initial program and connect via a "LINK" command.  
For this purpose, the temperature of the thermoblock is brought to 4 °C using the first program. After the samples have been inserted into the cold thermoblock, the second program with the PCR protocol is called up via a LINK command.

Programming should take place as follows:

<b>Program 1</b>	<b>e.g. COOL</b>
<b>CNTRL TUBE</b>	The entries in the first program are also valid for the programs which are added via LINK. The lid setting "Fix" must be selected.
<b>Lid</b>	
<b>NOWAIT FIX</b>	
<b>1 Hold 4 °C Enter</b>	The thermoblock cools until the processing program (e.g. PCRPROT) is started via the LINK command by pressing <input type="button" value="Enter"/> .
<b>2. Link PCRPROT</b>	Link to the second program with the PCR protocol.
<b>end</b>	
<b>Program 2</b>	<b>PCRPROT</b>
<b>CNTRL TUBE</b>	If the program also contains the "Tube control" command, further entries for tube type and filling volume are no longer necessary; the entries made for the first program are valid for all further programs.

## 8 Short instructions

It is essential to read the operating manual completely before working with the short instructions.

### Switching on the device

Menu name _____	Main-Menu		
To start any program _____	Start		
Programming _____	FILES ..		
System settings _____	OPTIONS ..		
To preheat the lid _____	Lid		
To temperature-control block and heated lid _____	Incubate		
Program in processing level _____	STANDARD		
Nominal/actual block temperature _____	--/25.0°	Lid:105°	10:22:06
Lid temperature (only when lid is switched on) _____			Time _____

### Programming

- Select the FILES menu using the  $\blacktriangle$  /  $\blacktriangledown$  keys and press .

To edit the program in the processing level _____	FILES ..		
To load and edit any program _____	Edit		
To load and process the example program _____	Load		
To create a new program _____	Standard		
To delete any program _____	New		
	Delete		
	STANDARD		
	--/22.0°		10:22:06

### Changing the "Standard" example program

- Select Standard using the  $\blacktriangledown$  key and press .
- Select the program commands using the  key, enter the settings or the texts and confirm by pressing .
- Using the  $\blacktriangle$ ,  $\blacktriangledown$ ,  $\blacktriangleleft$ ,  $\blacktriangleright$  keys, move the cursor to or between the entry positions.

CNTRL	To define temperature regulation
BLOCK	For the thermoblock
TUBE	For different tubes
Lid	To determine the lid temperature
NOWAIT	To start a program immediately
WAIT	Program waits for lid temperature
AUTO	Lid switches off at < 22 °C and time > 5 min.
FIX	Lid switches off at end of program

FILES ..	Edit STANDARD		
Edit		CNTRL	BLOCK
Load		LID=105°	
Standard		NOWAIT	AUTO
New	1	T=94.0°	0:02:00
Delete	2	T=94.0°	0:00:15
STANDARD	3	T=44.0°	0:00:15
--/22.0°			10:22:06

### Program commands

T	Temperatures, times, increments, ramp, gradient
HOLD	To maintain temperature entered until program is continued with <b>Enter</b> (4–99 °C)
PAUSE	To interrupt program (e.g. for addition of reagent) until program is continued with <b>Enter</b> (0–11 characters)
GOTO/REP	To repeat program parts and number of cycles (1–40 lines, 1–99 repeats)
SOUND	Acoustic signal (1–10 tones)
LINK	To branch to other programs (1–5 programs)

- Confirm entries by pressing .
- Enter the options for the temperature command using the  key. The cursor must be positioned on the program line number.





T	Temperature (0–99°), Time (0:00:01–9:59:59)
	Temperature increment ( $\pm 0.0$ – $\pm 10.0^\circ$ ), Time increment (0:01–1:00),
R	Ramp (0.3–3°C/s), Ramp increment ( $\pm 0.1$ – $\pm 1.0^\circ$ /s)
G	Gradient ( $\pm 10^\circ$ C) (for Mastercycler <sup>®</sup> gradient only)

FILES ..	STANDARD		
Edit	3	T=44.0°	0:00:15
Load	4	T=72.0°	0:00:30
Standard		+0.0°	+0:01
New		R= 3.0°/s	+0.0°/s
Delete		G=0.0°	
STANDARD	5	GOTO 2	REP 24
--/22.0°			10:22:06

- Complete programming by pressing .
- Save the program.



## 8 Short instructions

### Saving a program



- Exit the program using the  key.
- Answer the question "Save: YES" by pressing .
- Define the program name using the  key.
- Confirm the name by pressing .

FILES ..	Edit STANDARD
Edit	STANDARD not saved
Load	SAVE: YES
Standard	ProgName: STANDARD
New	
Delete	
STANDARD	
--/22.0°	10:22:06

### Adding a program line

- Using the  /  keys, move the cursor to the front of the line.
- Press the  key; a new line is then added above the cursor.









### Deleting a program line

- Using the  /  keys, move the cursor onto the program line number.
- Press the  key; the line is then deleted and the cursor moves to the next line.

### System settings

To temperature-control lid and block	Incubate menu	Block temperature 37 °C, Heater is ON
To preheat the lid	Lid menu	LidTemp 105 °C, Heater is ON
To print programming	OPTION menu	Printout Editor: YES
To print program sequence	OPTION menu	PrintProtocol: ON



### Starting a program

- Switch on the device. If necessary, preheat the lid and the block.
- Select the "Start" menu using the  /  keys and press .
- Select the program name using the  /  keys and press .
- With CNTRL TUBE, select the tube type using the  key. Enter the filling volume.  
0.2 ml/plate: 5 to 50 µl  
0.5 ml/thin: 5 to 100 µl
- Confirm by pressing .  
The program starts immediately.
- To see the program run time, press the  key.

Main-Menu	Run a Program:
Start	STANDARD
FILES ..	TEST1
OPTIONS ..	TEST2
Lid	
Incubate	
STANDARD	
--/25.0°	10:22:06



Main-Menu	Run a Program:
Start	1 T=95.0° 0:00:05
FILES ..	
OPTIONS ..	
Lid	
Incubate	
Running/STANDARD	Cyc:4
95.0/94.5°	Lid:105° 10:22:06

### Interrupting a program



- Press the  key.
- Using the  key, select the "Pause" program.
- Confirm by pressing .

Main-Menu	Run a Program:
Start	STANDARD running ...
FILES ..	Program: PAUSE
OPTIONS ..	
Lid	
Incubate	
Paused/STANDARD	
95.0/94.5°	Lid:105° 10:22:06

### Continuing an interrupted program

- Press the  key.
- Using the  key, select "Resume".
- Confirm by pressing .

### Stopping a program

- Press the  key.
- Confirm "Stop" by pressing .
- Exit the program by pressing .

Main-Menu	Run a Program:
Start	STANDARD running ..
FILES ..	Program: STOP
OPTIONS ..	
Lid	
Incubate	
STANDARD	
95.0/94.5°	Lid:105° 10:22:06

## 9 Personal card

Depending on the length of the program, a maximum of ten programs can be stored on a personal card. When a program is started from a personal card, the program is loaded into a temporary memory (but not into the internal memory or into the processing level) for the duration of the program processing.

Programs can be transferred to other devices of the Mastercycler<sup>®</sup>, Mastercycler<sup>®</sup> gradient and Mastercycler<sup>®</sup> personal using the personal card.

For the "Start", "FILES/Load", "FILES/Edit" and "FILES/Delete" menus, a difference will be made between the memory of the personal card (MCARD) and the internal memory of the Mastercycler<sup>®</sup> (INTERN) only when the personal card has been inserted.

Menus "Start", "FILES/Load" and "FILES/Delete"

Only the programs of a memory appear in the display. The memory which is currently closed appears in the display at the head of a program list as (INTERN) or (MCARD). The closed memory can be opened by selecting and then confirmed by pressing . This also closes the previous memory.

Menu "FILES/Edit"

The memory target (Target) must be selected using the  key before the program name is determined.

### 9.1 Safety precautions

The gold-colored contact area on the personal card must not be damaged, scratched or contaminated in any way. Avoid touching the contact area with your fingers.

Electrostatic charges can destroy stored programs.

### 9.2 Operation

#### **Inserting the card**

- With the arrow facing forwards and the gold-colored contact area facing upwards, insert the card into the slot under the control panel.
- Insert the card up to the stop. It clicks into place automatically.

#### **Removing the card**

- Insert the card up to the stop.
- The card is pushed out by spring pressure and can then be removed.

#### **Formatting the card**

A new card must be formatted. The request for formatting appears automatically in the display only when it is necessary. The request for formatting is also made if the card has been erroneously inscribed.

- "Memory card not valid"  
Confirm "Format: Yes" by pressing .

The nominal/actual steps appear in the bottom line of the display.

## 9 Personal card

### 9.3 Processing programs

#### Starting a program from a card

- Select the "Start" menu item and call up by pressing .
- Select ⟨MCARD⟩ and call up by pressing .  
If the memory name ⟨INTERN⟩ appears in the display instead of ⟨MCARD⟩, this means that the program memory of the personal card has already been opened.
- Select a program and call up by pressing .

**Note:** For starting purposes, programs are not loaded into the internal memory or into the "Edit" processing level. After the program has ended, the program which has been started by the card is no longer available on the device.

#### Deleting a program from a card

- Select the "FILES/Delete" menu and call up by pressing .
- Select ⟨MCARD⟩ and call up by pressing .  
If the memory name ⟨INTERN⟩ appears in the display instead of ⟨MCARD⟩, this means that the program memory of the personal card has already been opened.
- Select a program and delete by pressing .

#### Loading a program from a card into the processing level

- Select the "FILES/Load" menu and call up by pressing .
- Select ⟨MCARD⟩ and call up by pressing .  
If the memory name ⟨INTERN⟩ appears in the display instead of ⟨MCARD⟩, this means that the program memory of the personal card has already been opened.
- Select a program and load by pressing .

#### Saving a program on a card

- After a program has been compiled or modified, exit the processing level by pressing .
- Confirm the inquiry "Save: YES" by pressing .
- For the inquiry "Target:INTERN", select ⟨MCARD⟩ using the  key and confirm by pressing .
- Enter the program name (max. 8 characters) and confirm by pressing .

**Note:** The program can be saved under the same name as in the memory of the Mastercycler.

#### Programs with LINK commands

A program cannot be started from a personal card if it contains program branching – LINK commands – to other programs on the personal card. It is possible to start the program if branching to another program in the internal memory of the devices is available.

A program from the internal memory cannot call up a program from the personal card using a LINK command.

# 10 Interface description

## 10.1 Printer / PC connection

### Printer connection

The printer connection socket (25 pins, Centronics parallel interface, PC compatible) is located below the PC connection socket on the right-hand side of the device (see Sec. 4.1, Fig. 2.6).

Connect the Mastercycler<sup>®</sup> or Mastercycler<sup>®</sup> gradient and printer via a commercially available PC printer cable. The cyclers and printer must be switched off during installation. If the printer is not used frequently, the printer cable should be disconnected from the cycler port and only be installed when needed.

The parameters for the printer are set in the "OPTIONS/Printer" menu.

Print programming

**Printout Editor: NO**

Printing is switched off.

**Printout Editor: YES**

The program in the "Edit" menu is printed out.

Select "YES" using the  key and confirm by pressing .

"Printout Editor: NO" is selected automatically after the printout.

Print program protocol

**Print Protocol: OFF**

The program sequence is not printed out.

**Print Protocol: ON**

The program sequence is printed out.



# 10 Interface description

Example of a program printout:

```

** MASTER CYCLER gradient 5331 **
  Eppendorf-Netheler-Hinz GmbH
  Version x.xx.xx
  Time: 13:41:02
  Date: 14/Apr/1999
*****

LISTING
Program:      STANDARD      Program name
Created:      13/Apr/1999   11:46   Date last stored
Step:
  CNTRL      BLOCK
  LID=105C
  NOWAIT     AUTO
1  T = 94.0C   0:02:00
   +0.0C      + 0:00
  R = 3.0C/s  +0.0C/s
  G = 0.0C
2  T = 44.0C   0:00:15
   +0.0C      + 0:00
  R = 3.0C/s  +0.0C/s
  G = 0.0C
.
.
.
7  HOLD 22.0C ENTER
END OF LISTING
```

## 10 Interface description

Example of a program protocol:

Prior to the start, the program is printed (see page 46) and during the program sequence, all temperatures and times are printed in a protocol.

Program ... started at	-	Date and time of start of program
Initial Blocktemp	-	Block temperature at start
Initial Lidtemp	-	Lid temperature at start
Run Time	-	Estimated run time
Finish Time	-	Estimated time for end of program
Count	-	Count of program steps
Cycle	-	Count of cycles
Step	-	Program step no. from programming
Command	-	Command type and programmed values
Time	-	Time at end of a command
Completion Time	-	Time at end of program

```
Program STANDARD started at Date:      15/Apr/1999    7:56:12
Initial Blocktemp:      24.7 C
Initial Lidtemp:       25 C
Run Time:              1:26
Finish Time:           15/Apr/1999    9:22

Count   Cycle   Step   Command                               Time
                                     Tube:0.2 ml      Fill.Vol.:20 µl
                                     CNTRL          TUBE      7:56:21
                                     LID=105C
                                     NOWAIT AUTO   7:56:22
1       1       1      T=94.0C  0:02:00
          +0.0C  + 0:00
          R=3.0C/s +0.0C/s
          G=0.0C                               7:59:05
2       1       2      T=94.0C  0:00:15
          +0.0C  + 0:00
          R=3.0C/s +0.0C/s
          G=0.0C                               7:59:21
.
.
Completion Time:       15/Apr/1999    9:24:55

END OF PROTOCOL
```

## **10 Interface description**

### **PC connection**

The 9 pin PC connection socket (serial interface RS 232) is located above the printer port on the right-hand side of the device (see Sec. 4.1, Fig. 2.5).

The parameters for the computer are set in the "OPTIONS/GENERAL/Remote" menu.

Selection of transfer rate: Baud rate 19,200, 9,600, 4,800, 2,400 or 1,200

Detailed information about PC connection and the connecting cable required is available on request.

The computer to be connected must correspond to the EN 60950 or UL 1950 regulations.

A special operating manual is available for serial communication. Further information is available on request.

### **10.2 Program transfer**

If programs are stored on a personal card, they can be transferred via the card to other Mastercycler<sup>®</sup>, Mastercycler<sup>®</sup> gradient and Mastercycler<sup>®</sup> personal devices. Programs created on a Mastercycler<sup>®</sup> personal can also be transferred to a Mastercycler<sup>®</sup> gradient. The Mastercycler<sup>®</sup> gradient has an additional function, whereby a Gradient function is added to the temperature command, i.e. a temperature gradient can be built up in the thermoblock. This function cannot be used when programs are transferred to the Mastercycler<sup>®</sup> and Mastercycler<sup>®</sup> personal.

## 11 Maintenance

The devices do not require regular maintenance.

It can be cleaned using water or a mild laboratory cleaning agent.

The device should not come into contact with organic solvents or aggressive solutions. Ensure that no liquid enters the device. For safety reasons, the device must be switched off and disconnected from the power supply before cleaning begins.

The electrical safety fuses are located between the main power switch and the main power plug at the rear of the device. They can be removed by sliding them up one catch. Only fuses with the correct voltage values may be used (information on the fuse type can be found at the rear of the device).

The device may only be opened by qualified service personnel. The warranty will not be honored in the event of damage caused by unauthorized servicing.

## 12 Troubleshooting

Programming errors or errors regarding the handling of the personal card can be eliminated after the cause of the error has been established.

Technical errors can be caused by interference (e.g. power failure or power fluctuations). In some cases, it is possible to eliminate the error by switching off the device for a short period. Wait ten seconds before switching on the device again. If the error recurs, contact a service technician.

### 12.1 Error messages

<b>Error message</b>	<b>Cause</b>	<b>Solution</b>
<b>BLOCK ChkSumErr</b>	Technical defect.	Contact SERVICE.
<b>BLOCK TOO HOT!</b>	Defective regulation or defective electronics.	Contact SERVICE.
<b>Card changed</b>	Card removed immediately before being inscribed.	Insert card correctly and repeat procedure.
<b>Card content not o.k.</b>	Content of card is defective.	Card must be formatted. Automatic procedure when program is saved.
<b>Card not in slot</b>	Card removed during saving process.	Insert card correctly and repeat procedure.
<b>Enter Tube</b>	Not all entries have been made for a program which has been started.	Enter tube type and sample volume.
<b>Err GOTO (1)</b>	Branching to a program line number is impossible because this program line number is in a program area which has already been selected for repeating using another GOTO command.	Check GOTO command and modify or delete if necessary. Program line number for additional GOTO command must not be in a section which is already addressed by a GOTO command.
<b>Err GOTO (2)</b>	More than three GOTO commands used for one program range.	Three GOTO commands can be used in one program range when the areas which have been addressed overlay each other completely, i.e. the program area of the second command is greater than that of the first command. The third GOTO command must cover an even greater area than that of the second command.
<b>Err Invalid</b>	Invalid command. Parameter has not been entered.	Enter command completely or delete command.

## 12 Troubleshooting

<b>Error message</b>	<b>Cause</b>	<b>Solution</b>
Err Link (1) ... Line ..	LINK command cannot be executed. Program not found. Program name and program line of defective LINK command appear in the display.	Only programs from the internal memory can be called up by the LINK command. Programs on a personal card and the program in the processing level ("Edit") cannot be called up by the LINK command.
Err Link (2) ... Line ..	Too many programs are connected by LINK commands. Program name and program line of defective LINK command appear in the display.	A maximum of five programs, i.e. four LINK commands, can be processed in succession.
Err No Program	No executable program available in memory.	Load program from memory or personal card, or define a program in "Edit" menu and restart.
FAN ERROR!	Defective internal fan.	Switch off device. Contact SERVICE.
FAT Full	Number of programs which can be administrated has been exceeded. Internal memory: 99 programs personal card: 10 programs	Delete programs which are not required.
Internal EE-Err	Technical defect.	Contact SERVICE.
LEFT BLOCK DEFEKTIV!	Defective regulator or electronics on left-hand block.	Switch off device. Contact SERVICE.
LID TOO HOT!	Defective electronics.	Contact SERVICE.
Link not found	Program branching is not possible because the program which was supposed to be called up has been deleted.	Check the LINK command. Enter the missing program.
Link Error	Program branching is not possible because the program which was supposed to be called up has been deleted.	Check the LINK command. Enter the missing program.
MCard Error	The memory of the personal card is defective.	Evaluate further messages.
Memory corrupted	The internal memory is defective.	The internal memory must be deleted. This deletes all programs.

## 12 Troubleshooting

<b>Error message</b>	<b>Cause</b>	<b>Solution</b>
<b>Memory Error</b>	The internal memory for programs is defective.	Evaluate further messages.
<b>Memory full!</b>	Memory is full.	Before storing, delete programs which are not required.
<b>MemoryCard (Blank)</b>	Card has incorrect logical identification and/or is blank.	Card must be formatted. Automatic procedure when program is saved.
<b>MemoryCard Defective!</b>	Card is defective.	Use a new card.
<b>MemoryCard HdChecksumErr</b>	Error in check sum.	Card must be formatted. Automatic procedure when program is saved.
<b>MemoryCard ManIDErr</b>	Incorrect identification.	Card must be formatted. Automatic procedure when program is saved.
<b>MemoryCard MemOverErr!</b>	Incorrect memory address.	Card must be formatted. Automatic procedure when program is saved.
<b>MemoryCard MemRangeErr</b>	Error in memory range.	Card must be formatted. Automatic procedure when program is saved.
<b>MemoryCard MemSizeErr</b>	Incorrect memory size.	Card must be formatted. Automatic procedure when program is saved.
<b>MemoryCard MemUnderErr!</b>	Incorrect memory address.	Card must be formatted. Automatic procedure when program is saved.
<b>MemoryCard Missing!</b>	No card has been inserted.	Insert card.
<b>MemoryCard Not Valid</b>	Card is invalid.	<ul style="list-style-type: none"><li>– Insert card correctly (check that card is facing in the correct direction).</li><li>– Card should be formatted before saving begins.</li></ul>
<b>MemoryCard Read Err!</b>	Card cannot be read.	Insert card correctly (check that card is facing in the correct direction).

## 12 Troubleshooting

<b>Error message</b>	<b>Cause</b>	<b>Solution</b>
<b>MemoryCard Read-Only!</b>	Card is marked as write-protected.	Card must be formatted. Automatic procedure when program is saved.
<b>MemoryCard Write Err!</b>	Writing error on card.	<ul style="list-style-type: none"> <li>– Insert card correctly (check that card is facing in correct direction).</li> <li>– Do not touch/move card during saving.</li> </ul>
<b>MID BLOCK DEFEKTIV!</b>	Defective regulator or electronics on middle block.	Switch off device. Contact SERVICE.
<b>Name Invalid!</b>	Program name contains an invalid character.	Enter program name again.
<b>POWER ERROR!</b>	Voltage error or defective fuse.	Contact SERVICE.
<b>Printer: OFF LINE</b>	Printer is not ready to receive.	Select the "ON LINE" printer setting.
<b>Printer: no response</b>	No printer is available or the printer is not switched on.	<ul style="list-style-type: none"> <li>– Select "OFF" in the menu OPTION/Printer/Print Protocol.</li> <li>– Switch on the printer.</li> </ul>
<b>Program is running!</b>	A program is being processed.	Lid temperature cannot be modified at the moment.
<b>Program too large!</b>	Program is too large.	Max. 40 program lines possible.
<b>Restarting Program!</b>	A power failure occurs or the device is switched off briefly when a program is running.	The program continues automatically.
<b>RIGHT BLOCK DEFEKTIV!</b>	Defective regulator or electronics on right-hand block.	Switch off device. Contact SERVICE.
<b>SLOWING DOWN!</b>	The heating rate or cooling rate has slowed down.	If error recurs, contact SERVICE.
<b>Steps free</b>	Display of free memory spaces is < 100 steps. 1 step = 1 program line.	Delete programs which are not required or store them on the personal card.
<b>TSensor_Err</b>	<ul style="list-style-type: none"> <li>– Permitted operating conditions have not been maintained.</li> <li>– Technical defect.</li> </ul>	<ul style="list-style-type: none"> <li>– Operate device at permitted temperature and humidity only</li> <li>– Contact SERVICE.</li> </ul>



## 12 Troubleshooting

<b>Error message</b>	<b>Cause</b>	<b>Solution</b>
Value out of range!	Value is not within the permitted value range.	The closest permitted value is entered automatically.
Warn Ramp Max ... Line ...	The ramp is limited to 3 °C/s.	Check entries for ramp and ramp increment, and change entries if necessary.
Warn Ramp Min ... Line ...	The ramp is limited to 0.3 °C/s.	Check entries for ramp and ramp increment, and change entries if necessary.
Warn Temp Max	Temperature limits of 99 °C exceeded. If program is started, temperature is limited to 99 °C.	Check temperature commands and reduce value of temperature increment so that only values below 99 °C can be reached.
Warn Temp Min	Temperature limit of 4 °C not reached. If program is started, temperature is limited to 4 °C.	Check temperature commands and modify values of temperature increment so that only values above 4 °C can be reached.
Warn Time Max	Cycle time of 9:59:59 exceeded. If program is started, cycle time is limited to 9:59:59.	Check temperature commands and modify values of time increment so that only values below 9:59:59 can be reached.
Warn Time Min	Cycle time of 0:00:01 not reached. If program is started, cycle time is limited to 0:00:01.	Check temperature commands and modify values of time increment so that only values above 0:00:01 can be reached.

# 12 Troubleshooting

## 12.2 Test program

This program can be used to monitor the thermal and electrical functions of the built-in heating and cooling elements.



The basis of this program is the monitoring of individual factors which are necessary for setting specific temperatures for heating and cooling. The result is provided in the form of a number (index), which indicates the condition of these elements. The device status can be documented by repeating the test program at regular intervals.

### How to execute the program

All positions of the block of the Mastercycler® and Mastercycler® gradient remain empty (i.e. no tubes are inserted). The heated lid is closed but not locked. Please ensure that the device has been set up correctly. The test should take place at room temperature (22 °C); any deviations in the ambient conditions when the test is repeated should be recorded.

- Select the test program (Main-Menu/ OPTIONS../GENERAL../VALID.../ TEST) and confirm by pressing .

VALID . . . .	
Test	
Validate	
Calibrate	
UNNAMED	
- -/22°	10:22:01

- When a printer is connected, select "Use printer: YES" using the  key and confirm by pressing .

VALID . . . .	Test
Test	Use Printer: YES
Validate	
Calibrate	
UNNAMED	
- -/22°	10:22:02

- Start the program by pressing the  key.

**Note:** The duration of the program is approximately 25 minutes; no more entries are necessary during this period.

VALID . . . .	Test
Test	Status: Press Start
Validate	
Calibrate	
UNNAMED	
- -/22°	10:22:03

The program ends with an index value appearing in the display.

- Exit the program by pressing the  key.

VALID . . . .	Test
Test	Results:
Validate	Index: xx.xx
Calibrate	
UNNAMED	
- -0/22°	10:22:04

## 13 Technical data

### ***Mastercycler® / Mastercycler® gradient***

Sample capacity:	1 PCR plate 96 or 96 0.2 ml PCR tubes or 77 0.5 ml PCR tubes, thin-walled
Temperature range:	4 to 99 °C
Temperature uniformity across the block:	95 °C ± 1.0 °C 20 to 72 °C ± 0.6 °C
Control accuracy:	± 0.2 °C
Temperature-control speeds:	Heating rate: approx. 3 °C/s, measured on the block Cooling rate: approx. 2 °C/s, measured on the block
Number of programs:	max. 99 max. 10 on a personal card
Maximum number of cycles:	99
Dimensions:	Width: 26 cm Depth: 41 cm Height: 27 cm
Weight:	approx. 12.4 kg
Voltage/frequency:	230 V, 50–60 Hz / 115 V, 50–60 Hz / 100 V, 50–60 Hz
Power requirement:	500 W                      500 W                      500 W
Operating current:	2.6 A                      5 A                      6 A
Fuses:	2 x T 5 A, 250 V    2 x T 6.3 A, 250 V    2 x MT 8 A, 250 V
Overvoltage category:	II
Pollution degree:	2
Contamination level:	I
Operating conditions:	15 to 35 °C, 70 % rel. humidity
Storage conditions:	–20 to 70 °C, 85 % rel. humidity

The device is -approved, fulfills UL 3101-1 and CSA C 22.2 No. 1010.1.

Technical specifications subject to change!

## 14 Ordering information

Please use only the accessories recommended by Eppendorf. Using disposables which we have not recommended can reduce the precision, accuracy and life of the device. We do not honor any warranty or accept any responsibility for damage resulting from such action.

<b>Order no.</b>	<b>Description</b>
5333 000.018	Mastercycler® 230 V, 50–60 Hz
5333 000.026	115 V, 50–60 Hz
5333 000.034	100 V, 50–60 Hz
5331 000.010	Mastercycler® gradient 230 V, 50–60 Hz
5331 000.045	115 V, 50–60 Hz
5331 000.037	100 V, 50–60 Hz
<b>Accessories</b>	
0013 609.349	Fuse, time-lag, 5 A, 250 V (1 pc.) for 230 V
0013 565.333	Fuse, time-lag, 6.3 A, 250 V (1 pc.) for 115 V
0013 611.432	Fuse, semi time-lag, 8 A, 250 V (1 pc.) for 100 V
5331 350.011	<i>in situ</i> Adapter
5331 900.011	Operating manual in German and English for Mastercycler® and Mastercycler® gradient
5332 300.018	Personal card
5331 226.027	Personal card for temperature-validation system
5331 225.004	Surface temperature sensor for <i>in situ</i> Adapter *
5331 222.005	Temperature-validation system
5331 224.008	Temperature sensor for 0.2 ml tube positions
5331 223.001	Temperature sensor for 0.5 ml tube positions
<b>Consumables</b>	
0030 127.498	Cap Strips (8-strips) (25 x 12 pcs.)
0030 127.650	Heat Sealing Film (100 sheets)
0030 127.633	Heat Sealing Foil (100 sheets)
0030 127.501	<i>in situ</i> Frames, 25 µl (100 pcs.)
0030 127.510	<i>in situ</i> Frames, 65 µl (100 pcs.)
0030 127.528	<i>in situ</i> Frames, 125 µl (100 pcs.)
0030 127.536	<i>in situ</i> Frames, 300 µl (100 pcs.)
0030 127.307	PCR plate 96, colorless (25 pcs.) (different colors available; see General Catalogue)
0030 127.056	PCR plate 96, low volume, colorless (25 pcs.) (different colors available; see General Catalogue)
0030 127.374	PCR plate 96, skirted, colorless (30 pcs.) (different colors available; see General Catalogue)

\* Minimum software requirement for *in situ* reactions: Version 2.0

## 14 Ordering information

### **Consumables**

0030 127.480	PCR Film, adhesive (100 sheets)
0030 127.471	PCR Foil, adhesive (100 sheets)
0030 124.200	PCR tubes, 0.2 ml, colorless (1000 pcs.)
0030 124.502	PCR tubes, 0.5 ml, colorless, thin-walled (500 pcs.)
0030 124.227	PCR tubes 0.2 ml, colorless, 8-strip (8 x 125 pcs.)
0030 121.023	Safe-Lock microcentrifuge tubes, 0.5 ml, colorless (500 pcs.)
0030 127.463	Sealing Mat 96 (5 pcs.)

### **Recommended auxiliary equipment**

5425 715.005	Adapter for 0.2 ml PCR tubes for 1.5/2.0 ml rotor (6 pcs.)**
5425 716.001	Adapter for 0.5/0.6 ml tubes for 1.5/2.0 ml rotor (6 pcs.)**
0030 127.153	Capping Aid, sealing PCR tubes and plates (1 pc.)
4830 000.017	Eppendorf Biomaster <sup>®</sup> 4830 and Mastertips <sup>®</sup> for contamination-free pipetting according to the positive-displacement principle in the volume range from 1 µl to 20 µl Biomaster Kit = 1 Biomaster and 96 Mastertips
0030 127.641	Foil Stripper
0030 124.243	Frame for work tray (set of 5)
5390 000.016	Heat Sealer 115 V / 60 Hz
5390 000.024	Heat Sealer 230 V / 50 Hz
0030 127.455	PCR Rack, random colors (10 pcs.)
0030 124.235	Work tray for 0.2 ml PCR tubes (set of 10 )

### **PCR Reagents**

0032 003.001	dNTP (Deoxynucleotide) Mix, 10 mM (200 µL)
0032 003.109	dNTP (Deoxynucleotide) Mix, 10 mM (1000 µL)
0032 003.206	dNTP set (Deoxynucleotides), set of 4, 100 mM (4 x 100 µL)
0032 003.303	dNTP set (Deoxynucleotides), set of 4, 100 mM (4 x 250 µL)
0032 002.404	MasterTaq Kit (100 U)
0032 002.501	MasterTaq Kit (250 U)
0032 003.702	MasterTaq Kit (1000 U, 4 x 250 U)
0032 002.200	Taq DNA Polymerase (100 U)
0032 002.307	Taq DNA Polymerase (250 U)
0032 003.508	Taq DNA Polymerase (1000 U, 4 x 250 U)

\*\* For centrifugation

# 15 Index

## **A**

Actual temperature 22  
Annealing 31

## **B**

Baud rate 15  
BLOCK 18, 25  
Brightness regulator 6

## **C**

Command  
    AUTO 26, 41  
    CNTRL 20, 22, 25, 41  
    FIX 26, 41  
    GOTO 28, 50  
    GOTO/REP 41  
    HOLD 28, 32, 40  
    LINK 28, 44, 51  
    NOWAIT 20, 26, 41  
    PAUSE 28, 37  
    SOUND 28  
    WAIT 20, 26, 41  
Creating new programs 29  
Cursor 7, 8, 31, 34  
Cycle 31  
    time 26, 54

## **D**

Display 8  
Denaturation 29, 30, 31

## **E**

Elongation 29, 31  
END 29  
Entering date 15  
Example program 11, 35, 41

## **F**

Filling volume 22, 25

## **G**

Gradient 3, 4, 14, 26, 27, 29, 31, 36

## **H**

Heated lid 4, 17, 18, 20, 26

## **I**

*in situ* Adapter 3, 19  
INTERN 43, 44

## **L**

Locking button 6

## **M**

Main menu 8, 9, 21, 22  
Main power switch 6  
Maintenance 49  
MCARD 43, 44  
Menu  
    Delete 11, 41  
    Edit 10, 41  
    Editor 12, 45  
    FILES 10  
    GENERAL 15  
    Gradient 13  
    Incubate 18, 20, 41  
    Lid 17, 26  
    Load 11, 41  
    New 11, 30, 41  
    OPTIONS 12, 45  
    Printer 13  
    Standard 11, 35  
    Start 10  
    VALID 16

## **N**

Nominal temperature 22, 26

## **O**

Ordering information 57

## **P**

Pause 23, 24, 42  
PC connection socket 6  
Peltier element 3  
Personal card 5, 43, 50, 52  
    reader 6  
Power failure 15  
Printer connection socket 6, 45  
Processing level 8, 9, 10, 11, 21, 33, 41, 44  
Program  
    line, adding 34  
    line, deleting 34  
    line number 22, 26, 28, 31, 41, 42  
    name 10, 11, 21, 32, 44  
    sequence 47  
    sequence, printing 42, 45  
    – aborting 8, 24, 42  
    – changing 33, 34  
    – continuing 24, 42  
    – deleting 35, 41  
    – interrupting 8, 23  
    – loading 33  
    – saving: see "storing"  
    – starting 21  
    – storing 10, 32, 42  
    – transferring 48

# 15 Index

## **R**

Ramp 26, 27, 39, 41, 54  
Ramp increment 26, 27, 41, 54  
Restart 15  
Resume 24, 42  
Reverse sign 7  
Run 23  
Run time 7, 17, 23

## **S**

Safety precautions 4, 43  
Sample  
    quantity 20  
    tube 19  
Setting the time 15  
Signal 15  
Startup 4, 5  
Stop 23, 24

## **T**

Temperature 14, 22, 26, 28, 30, 41, 54  
    increment 26, 27, 38, 39, 41, 54  
    options 12  
Thermoblock 3, 4, 14, 18, 19, 20  
Time increment 26, 27, 38, 41, 54  
Tube control 3, 25  
Tube type 20, 22, 42

## **V**

Ventilation 4  
    slit 5, 6

Eppendorf Scientific, Inc.  
One Cantiague Road,  
P.O. Box 1019  
Westbury,  
New York 11590-0207  
(USA)  
Phone 800-421-9988  
Fax 516-876-8599  
e-mail: [eppendorf@eppendorfsi.com](mailto:eppendorf@eppendorfsi.com)

**eppendorf**  
— *Scientific* —



# Support and Services Directory

## Contact Information

### United States

### Canada



**Business Hours:**

8:30 a.m. to 6:00 p.m. EST

8:30 a.m. to 6:00 p.m. EST



**Phone:**

800-645-3050

800-263-8715

516-334-7500

905-826-5525

**Fax:**

516-334-7506

905-826-5424



**Address:**

Eppendorf North America, Inc.  
One Cantiague Road  
Westbury, NY 11590-0207

Brinkmann Instruments (Canada) Ltd.  
6670 Campobello Road  
Mississauga, ONT L5N 2L8



**Website:**

[www.eppendorf.com](http://www.eppendorf.com)

[www.brinkmann.com](http://www.brinkmann.com)

**Email:**

[info@eppendorf.com](mailto:info@eppendorf.com)

[canada@brinkmann.com](mailto:canada@brinkmann.com)



**Customer Support:**

800-645-3050, menu option 2  
[custserv@eppendorf.com](mailto:custserv@eppendorf.com)

800-263-8715, menu option 1  
[custserv@brinkmann.com](mailto:custserv@brinkmann.com)



**Repair:**

800-645-3050, ext. 2404  
[service@eppendorf.com](mailto:service@eppendorf.com)

800-263-8715, ext. 232  
[service@brinkmann.com](mailto:service@brinkmann.com)



**Applications Lab:**

800-645-3050, ext. 2258  
[apps@eppendorf.com](mailto:apps@eppendorf.com)

800-645-3050, ext. 2258 (U.S.)  
[bioapps@brinkmann.com](mailto:bioapps@brinkmann.com)

For more information contact your Eppendorf North America Sales Representative at 800-645-3050.

**eppendorf**  
*In touch with life*

[www.eppendorf.com](http://www.eppendorf.com) • Email: [info@eppendorf.com](mailto:info@eppendorf.com) • Application hotline: 516-515-2258

In the U.S.: Eppendorf North America, Inc. 800-645-3050 • In Canada: Brinkmann Instruments (Canada) Ltd. 800-263-8715